



Wiring Harness Replacement Instructions

STOP! DO NOT DISCONNECT ANY HARNESS WIRES UNTIL YOU HAVE FULLY READ THESE INSTRUCTIONS!

Step 1 - Remove the Control Box

1. Unplug the kiln.
2. Remove the screws on the left side of the control box that secure it to the lid
3. Remove the numbered element feeder wires and labeled thermocouple wires from the terminal strip
4. Lift the control box off the kiln and place it (controller face down) on a flat protected surface
5. Remove the baffle screws located on both sides of the control box
6. Carefully lift the baffle out of the box and roll it over the side. It will still be connected by relay and thermocouple wires on the inside, so be careful not to strain those connections.

Step 2 - Determine which Wiring Diagram to use

The wiring diagram that you need to use will be determined by 4 factors:

1. Controller Version - 200, 300, 600 or 700
2. Relay Type - Deltrol or Potter & Brumfield
3. Kiln Model
4. Phase - 1 PH or 3 PH

Controller Type

Identify which controller you have by number and location of tabs on the back of your controller.

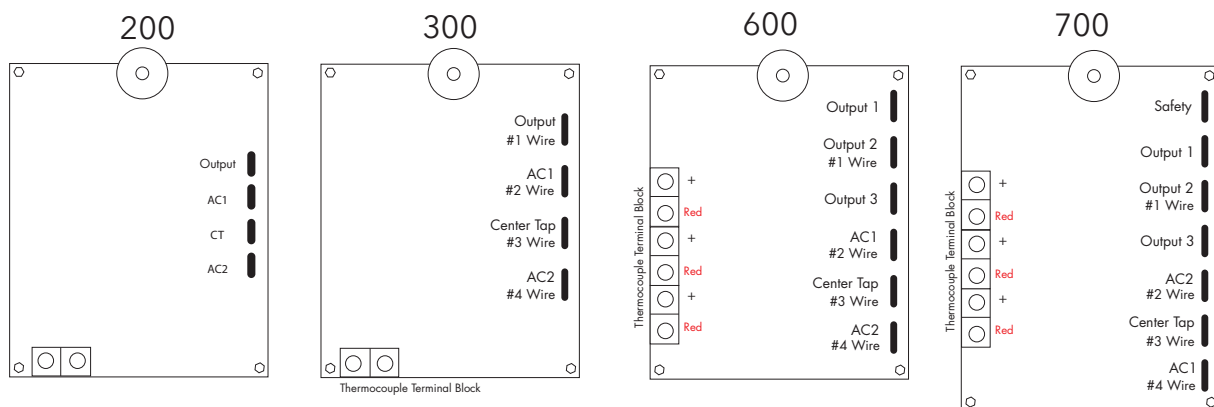

WIRING HARNESS REPLACEMENT INSTRUCTIONS CONTINUED

Relay Type

Identify your relay type. Deltrol Relays have a clear plastic case and the connections are made on the end of the relay. Potter Brumfield Relays are black and the connections are made on the face of the relay.

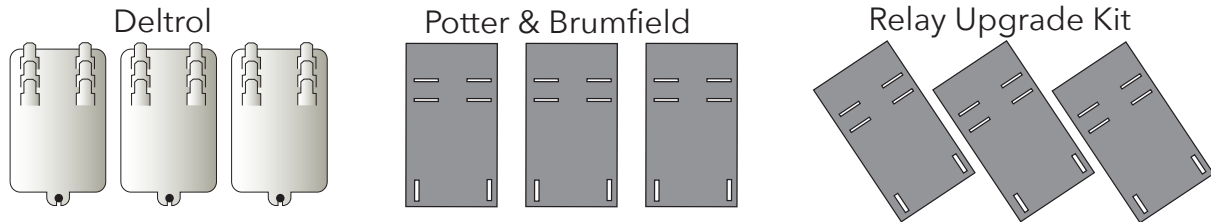
**If you have a Relay Upgrade Kit installed**

We are suggesting you revert back to the Deltrol Relays with the new and improved harness wire set. If you have a Relay Upgrade Kit installed, remove the adapter plate used to angle the relays and mount the new Deltrol Relays straight up and down as before the upgrade.

Note: Some customers unknowingly installed Relay Upgrade Kits on models that did not require it. If your controller box has 6 louvers on the top (instead of 5) you are one of these people and should continue to use the Potter & Brumfield relays with the new 12 gauge harness wire set. Use the wiring diagram for your recommended relay.

Kiln Model & Phase Identification

The phase and Model # are designated on the serial plate on the side of the control box.

Step 3A - Relay and Harness Wire Removal

1. It may NOT be necessary to replace wires #5, #6 and #7 unless they are compromised. These are connected to the transformer and fuse holder; both of which can be damaged if not handled with care. Disregard relay replacement references in the following instructions if you are only changing your harness wires.
2. Using a Phillips screwdriver, remove the wires attached to the heat baffle terminal strip. Save your screws. If you want to get the heat baffle entirely out of the way, remove the remaining red and yellow thermocouple wires.
3. Begin removal of the old relays from the control box by removing the sheet metal screws holding the relays in place. Save your screws. All wires, both white(black on older units) and red, connected to the relays will be removed. With the relays loosened, remove the two large screws on the terminal block holding the relay wiring in place. The wires at this point should be crimped into two large silver connectors that also will contain one red wire each. Follow each red wire and remove the push-on connectors from the fuse holder and the transformer bottom tab. Use a gentle side to side rocking and pulling motion to remove these connectors. Be especially careful when removing the connector from the transformer to avoid damaging it. Remove the red connector from the top-center transformer tab also. Remove the double red wire on the circuit board labeled center tab. Carefully pull the relays and all attached wires out of the control box.
4. Refer to image #1 to ensure that all of the relays and proper wiring have been removed.

WIRING HARNESS REPLACEMENT INSTRUCTIONS CONTINUED

Installing New Relays and Harness Wires

1. Install new relays using the old sheet metal screws you saved earlier. See diagram for proper orientation.
2. Use Wire Identification Sheet in conjunction with the Wiring Diagram to install the wires in their correct position. The wires are numbered on the Wire Identification Sheet and Diagram to make this easier. It is easier if you begin with all the red control wires. Make sure all the connectors are tight.
3. Reinstall the baffle
4. Re-hang the control box, attach the wires to the terminal strip and secure with screws.
5. Plug in the kiln and perform a test firing to make sure everything is operating correctly.

WIRING HARNESS REPLACEMENT INSTRUCTIONS CONTINUED

Wire Identification Sheet
KM 1027
KM1227
GM1414
1 Phase

2560

#1

(2 each)

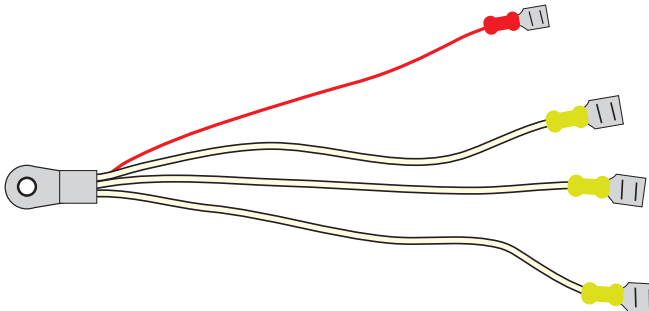

#2

(6 each)



#3

(1 Each)

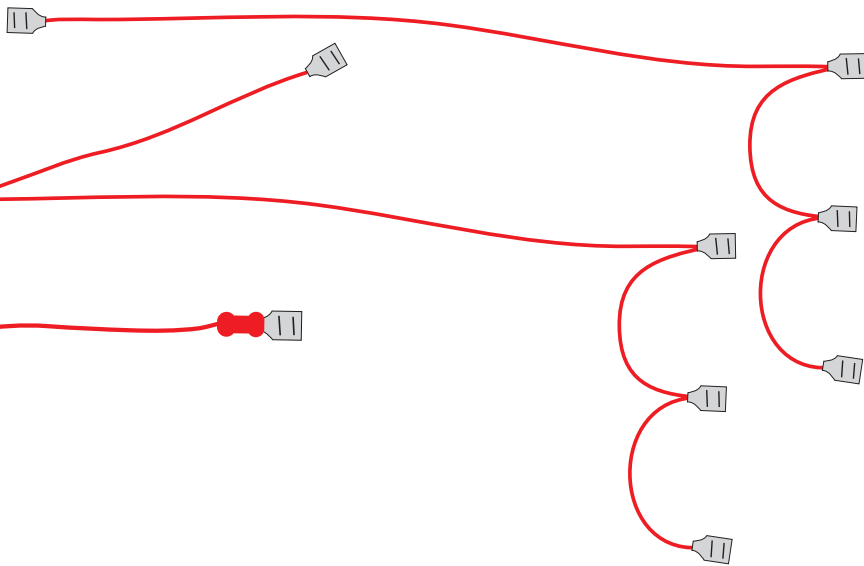

#4

(1 each)

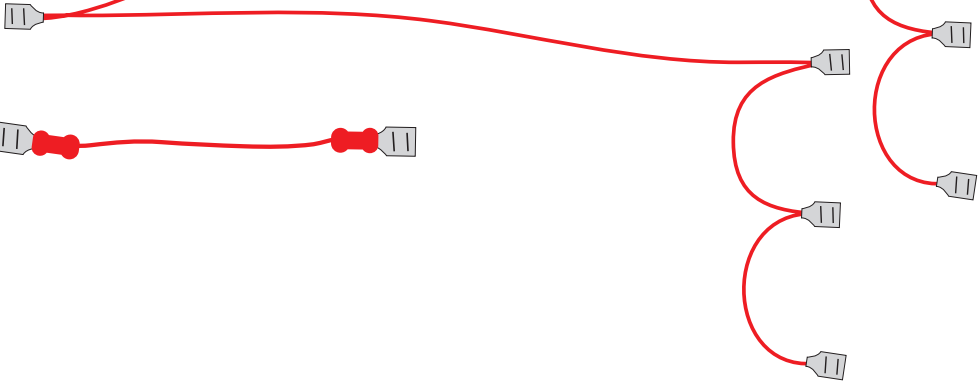

#5

(1 each)



#6

(1 each)



#7

(2 each)



#8

(3 each)



WIRING HARNESS REPLACEMENT INSTRUCTIONS CONTINUED

Wiring Harness (Deltrol Relays)
200 Board
KM1027
KM1227
1 Phase

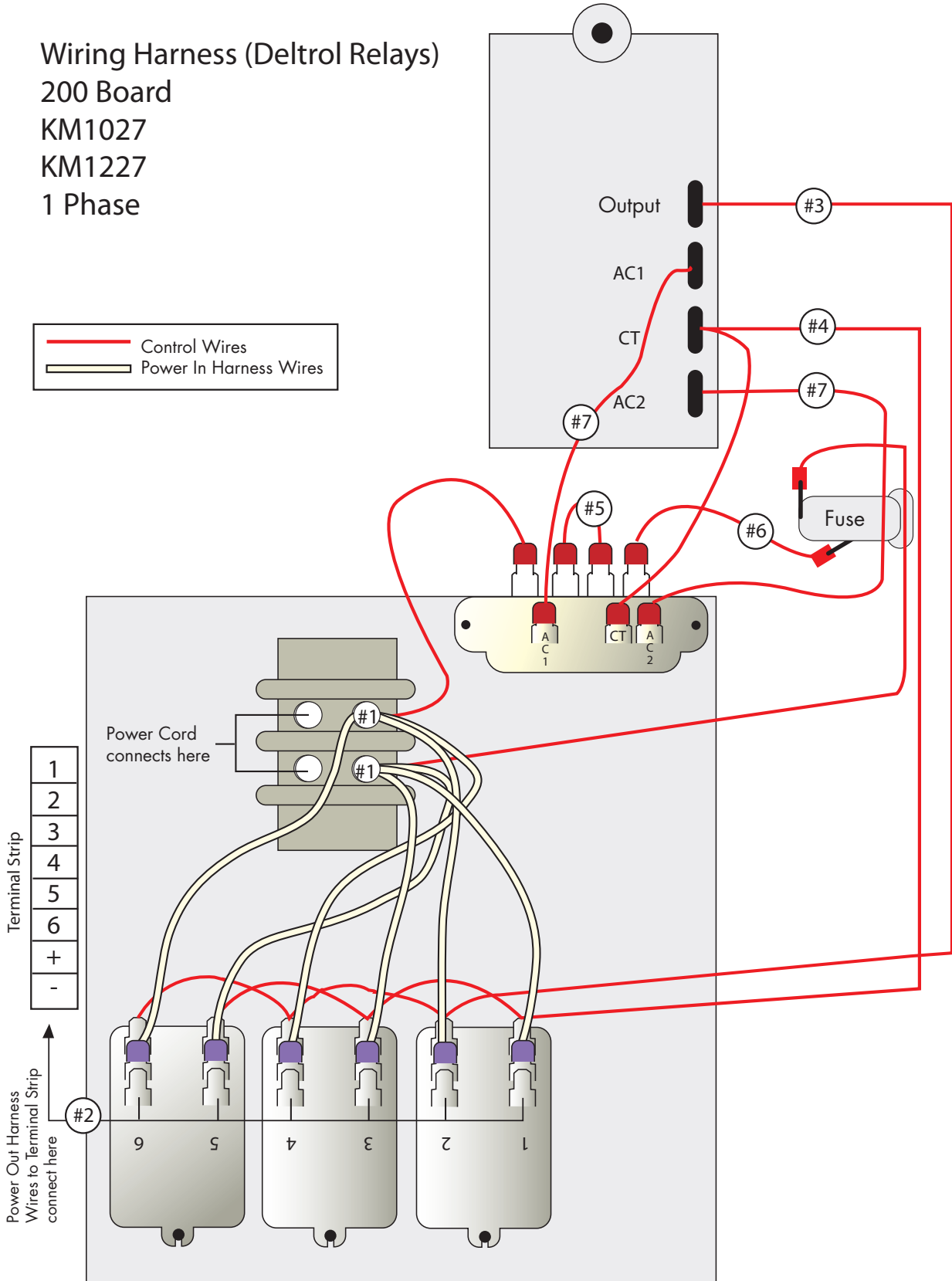

REPAIRS

WIRING HARNESS REPLACEMENT INSTRUCTIONS CONTINUED

Wiring Harness (Deltrol Relays)
300 Board
KM1027
KM1227
1 Phase

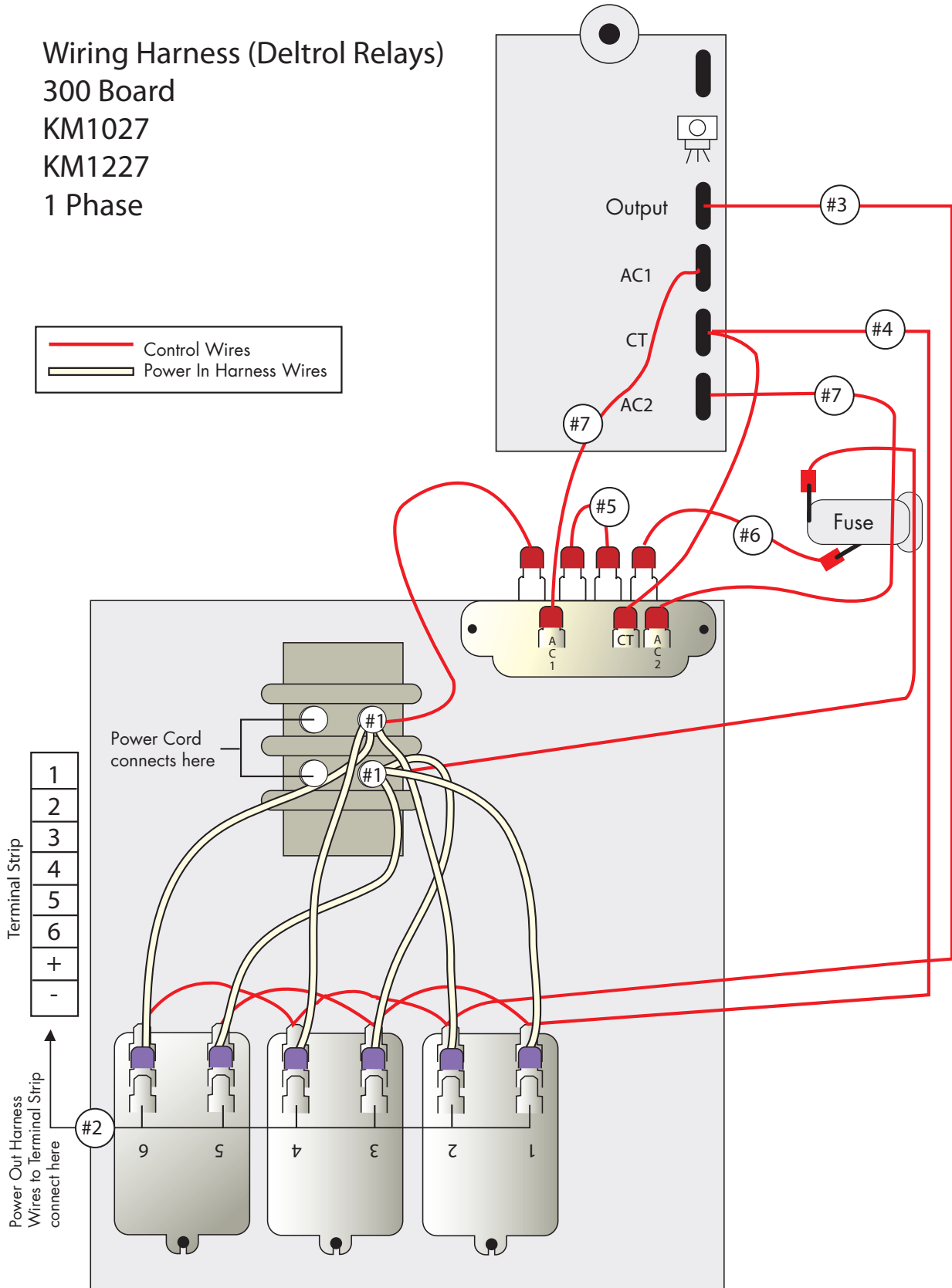

WIRING HARNESS REPLACEMENT INSTRUCTIONS CONTINUED

Wire Harness (Deltrol Relays)
600 Board
KM1027
KM1227
GM1414
1 Phase

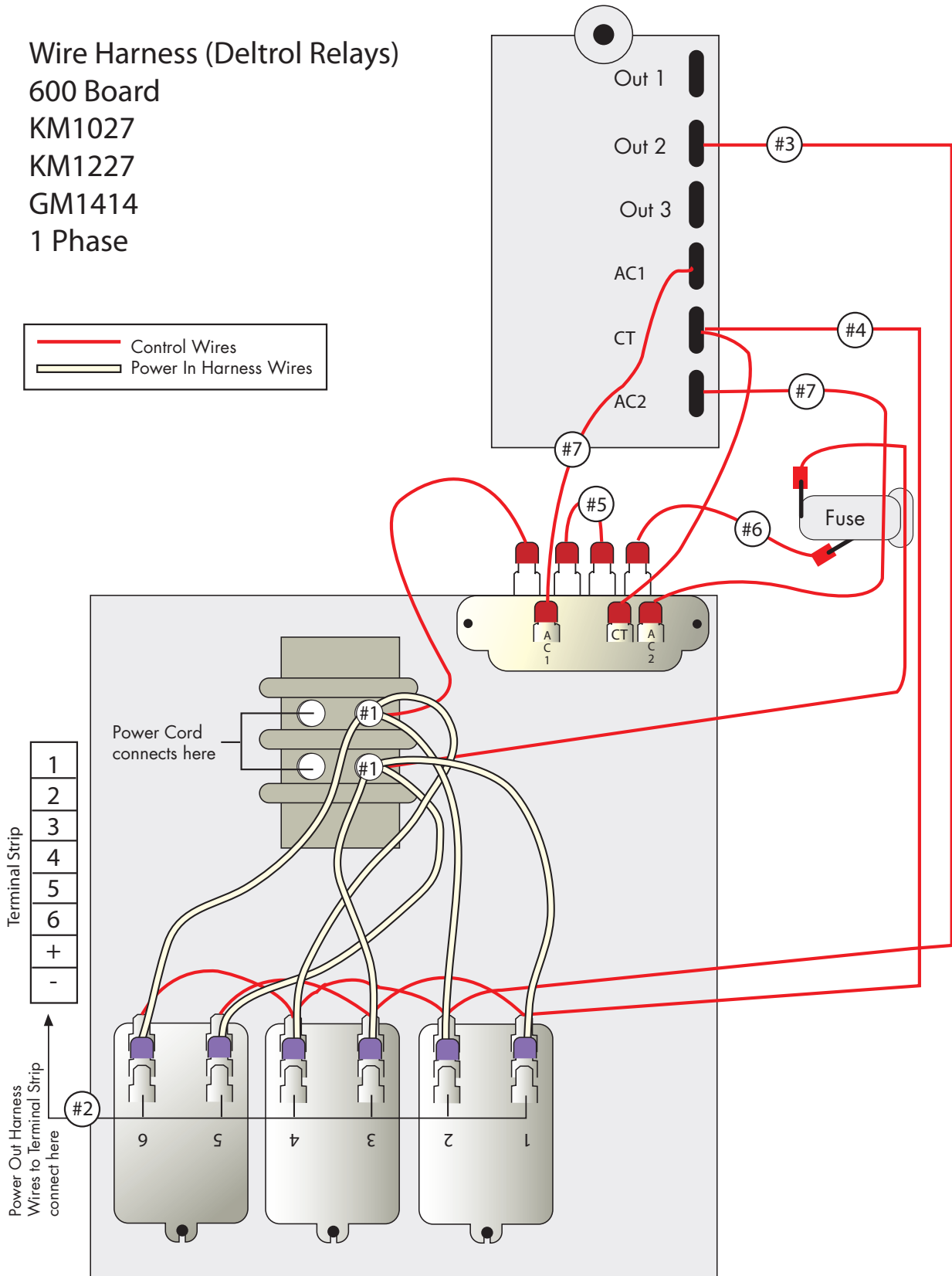
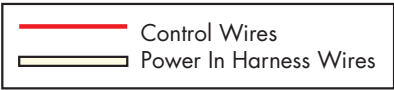

REPAIRS

WIRING HARNESS REPLACEMENT INSTRUCTIONS CONTINUED

Wiring Harness
(Potter & Brumfield)
600 Board
KM1027
KM1227
GM1414
1 Phase

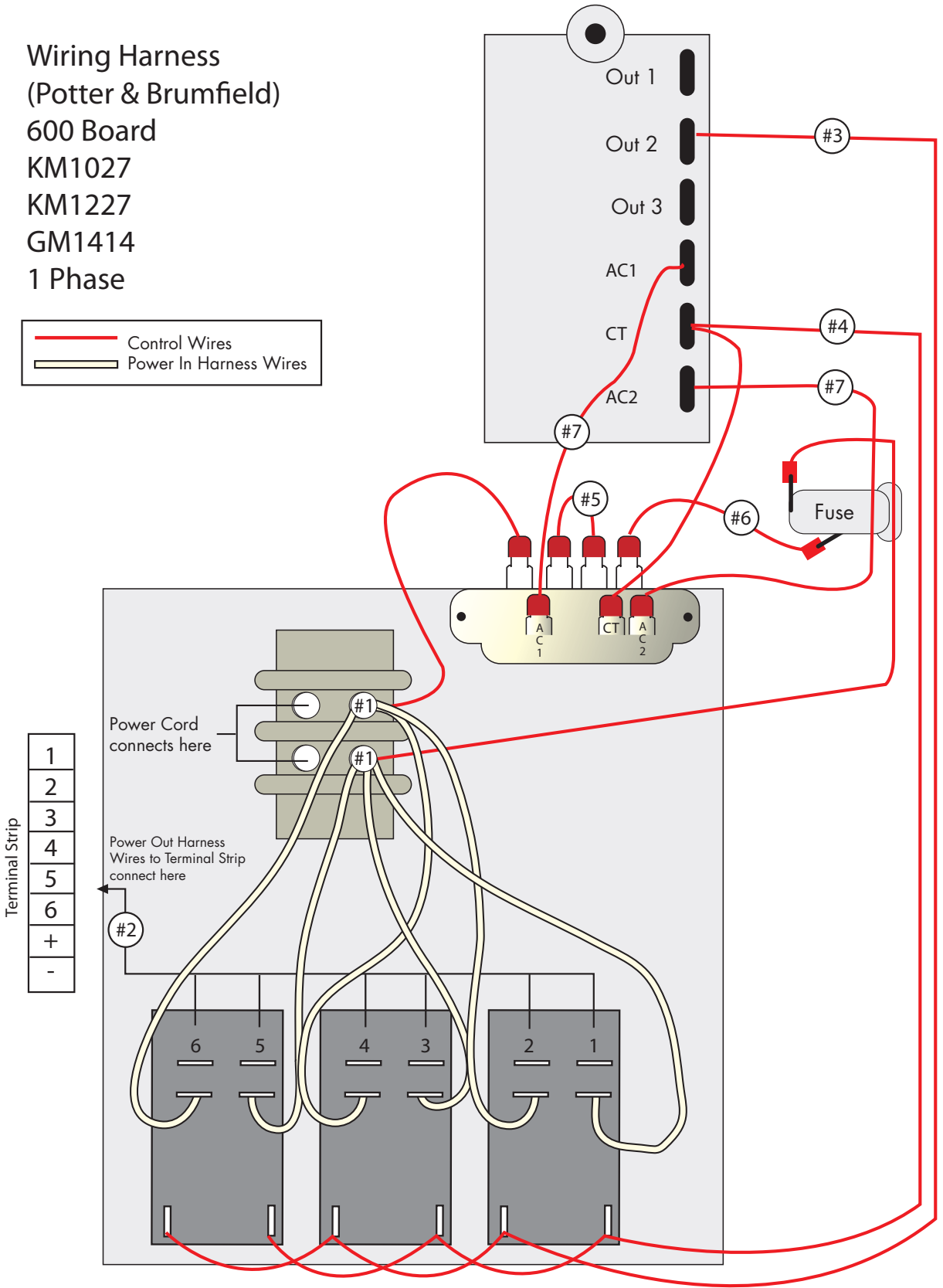
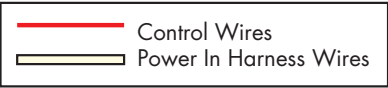

REPAIRS

WIRING HARNESS REPLACEMENT INSTRUCTIONS CONTINUED

Wiring Harness
(Potter & Brumfield)
700 Board
KM1027
KM1227
GM1414
1 Phase

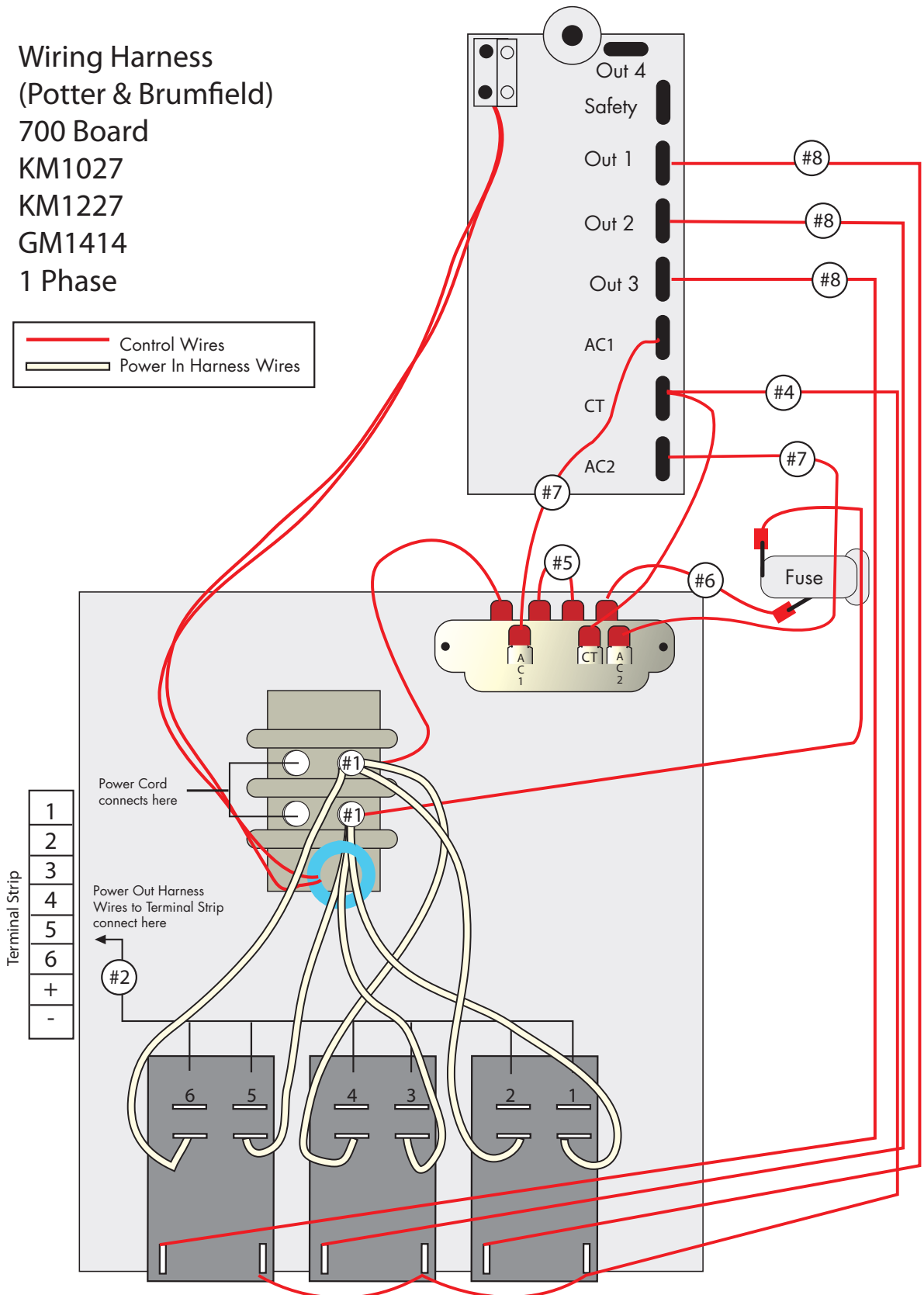

REPAIRS

WIRING HARNESS REPLACEMENT INSTRUCTIONS CONTINUED

Wire Identification Sheet
KM1027
KM1227
GM1414
3 Phase

2561

#1

(6 each)



#2

(6 each)



#3

(1 each)



#4

(1 each)



#5

(1 each)



#6

(1 each)



#7

(2 each)



#8

(3 each)



#9

(2 each)

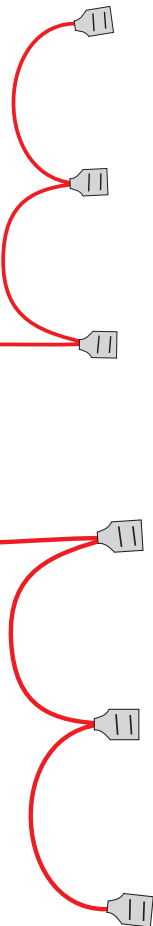

WIRING HARNESS REPLACEMENT INSTRUCTIONS CONTINUED

Wiring Harness (Deltrol Relays)
200 Board
KM1027
KM1227
3 Phase

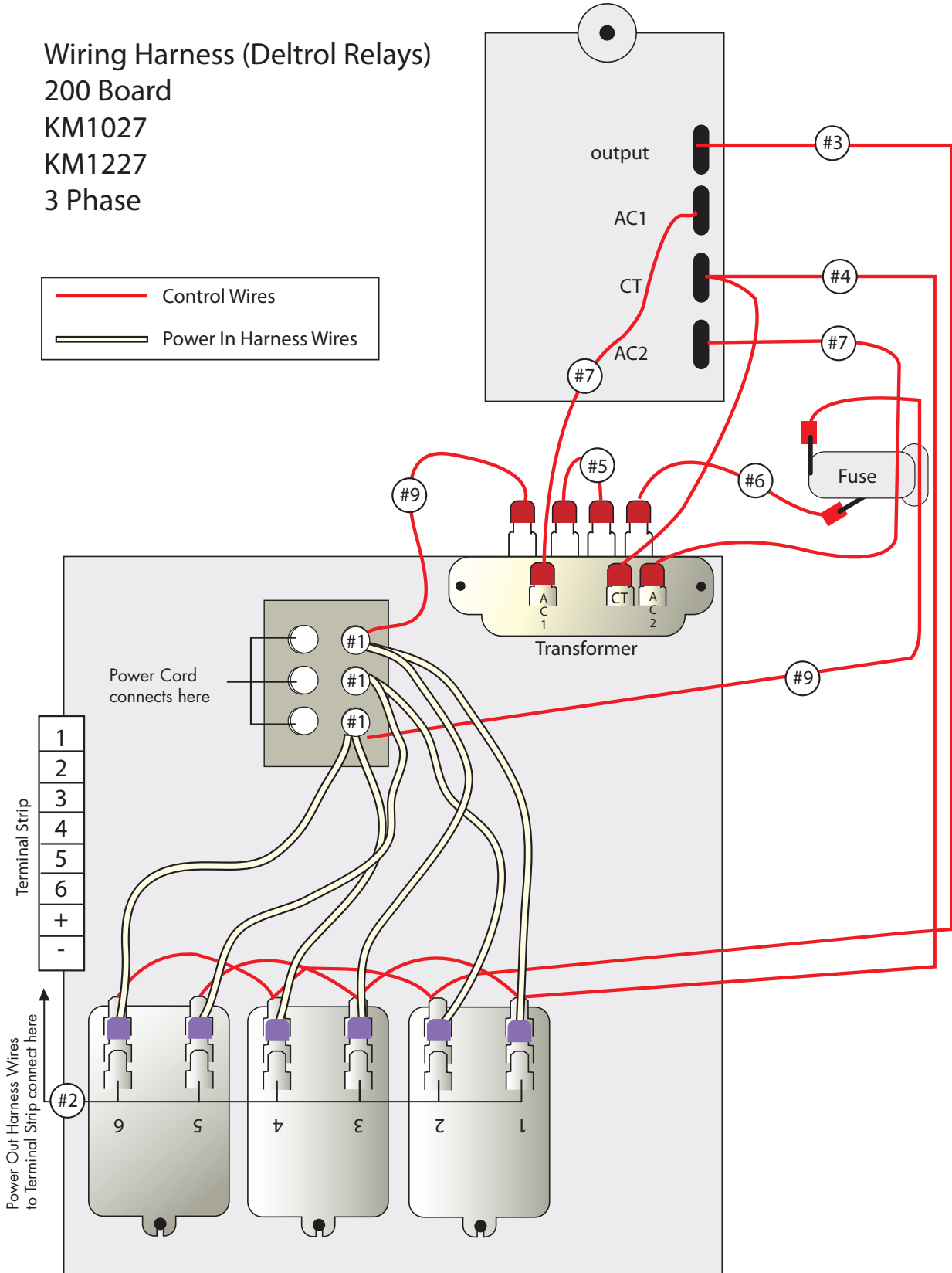
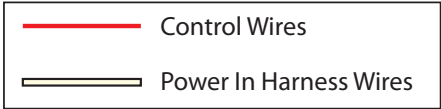

REPAIRS

WIRING HARNESS REPLACEMENT INSTRUCTIONS CONTINUED

Wiring Harness (Deltrol Relays)
300 Board
KM1027
KM1227
3 Phase

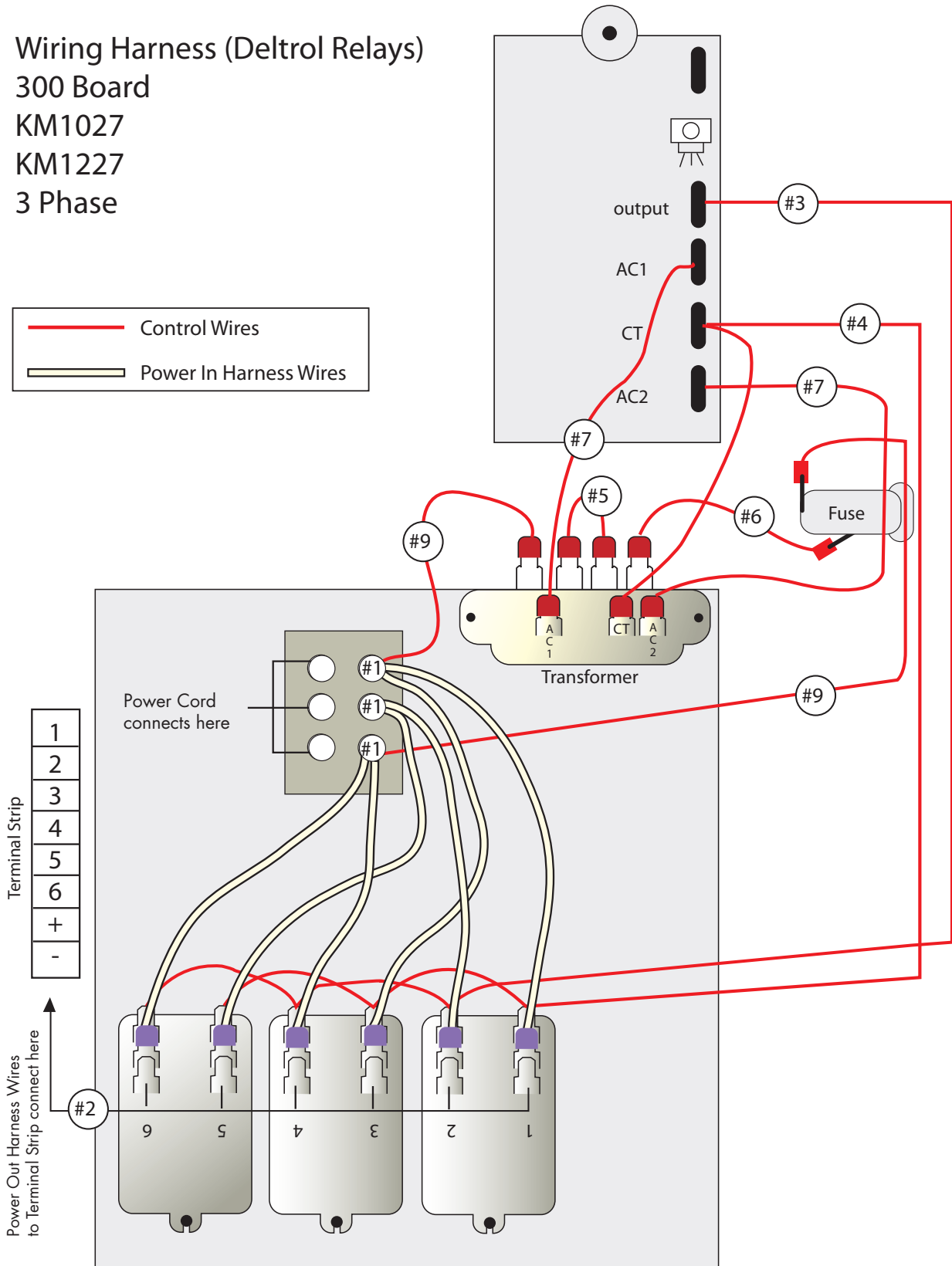
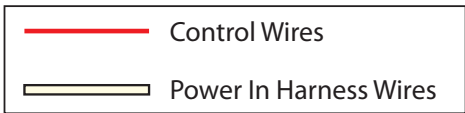

REPAIRS

WIRING HARNESS REPLACEMENT INSTRUCTIONS CONTINUED

Wiring Harness (Deltrol Relays)
600 Board
KM1027
KM1227
GM1414
3 Phase

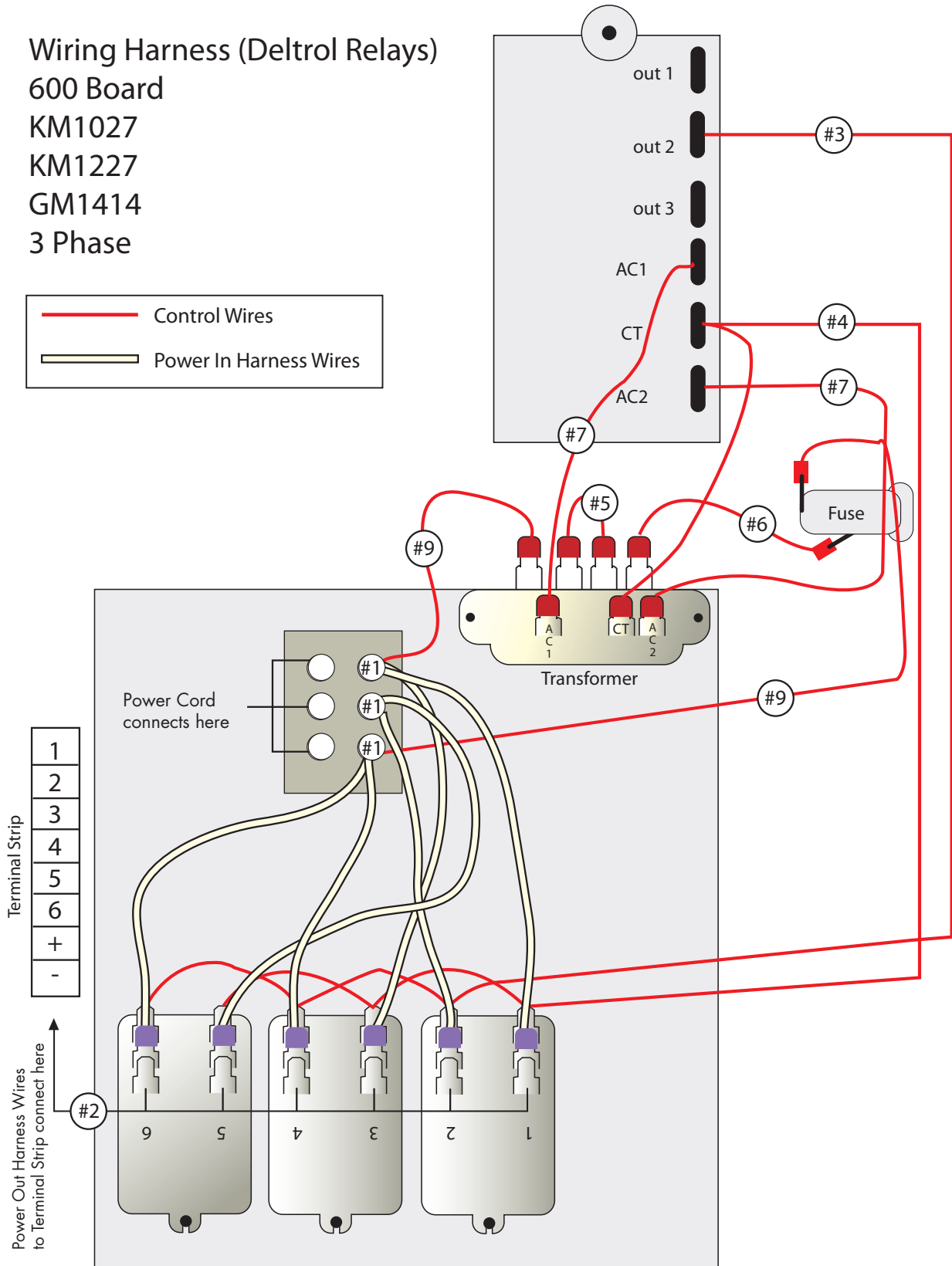
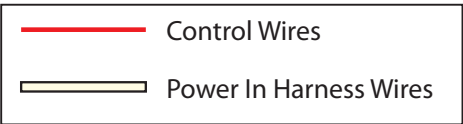

REPAIRS

WIRING HARNESS REPLACEMENT INSTRUCTIONS CONTINUED

Wiring Harness
(Potter & Brumfield)
600 Board
GM1414
KM1027
KM1227
3 Phase

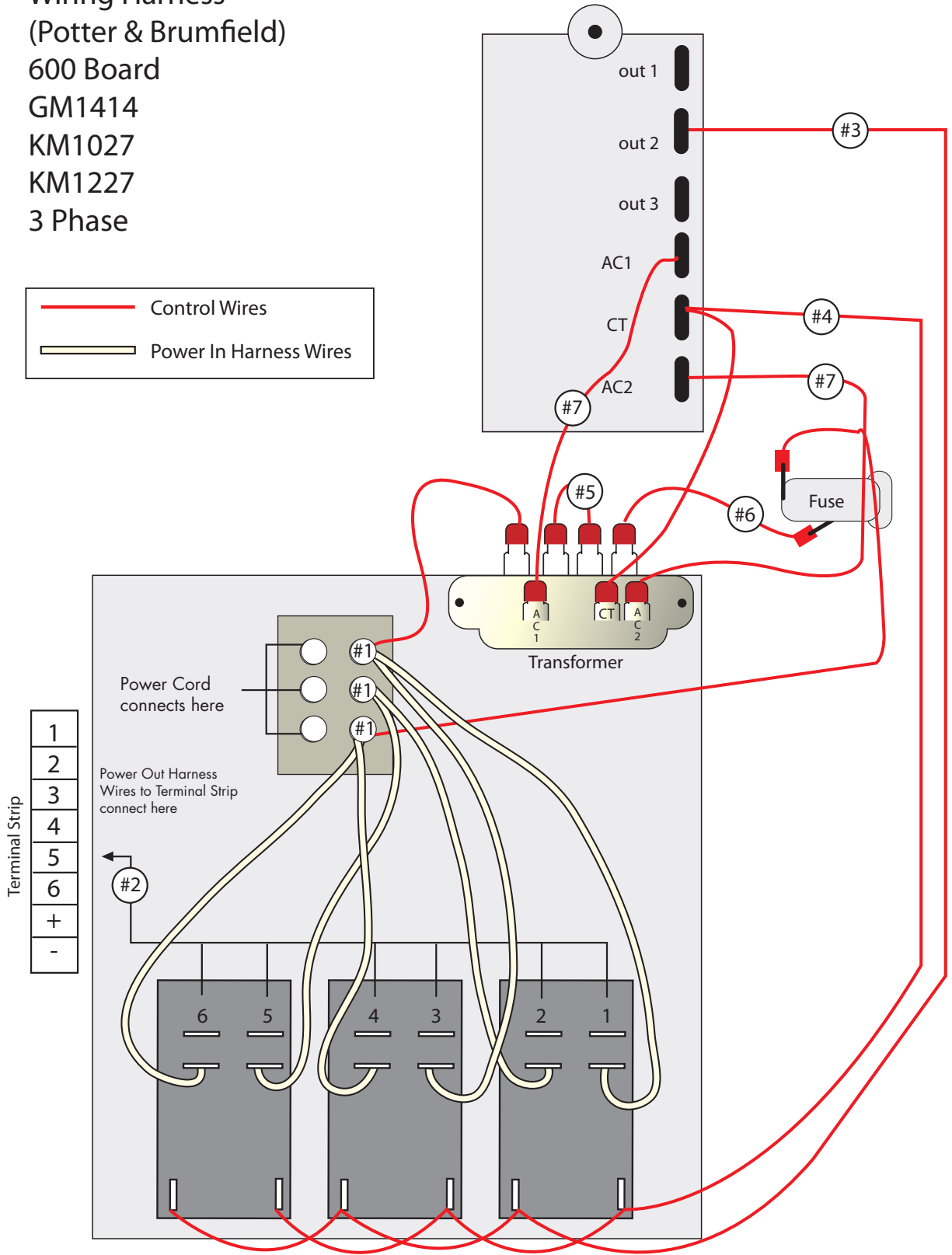
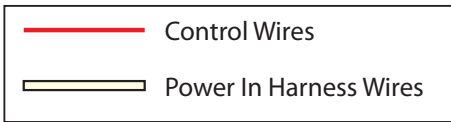

WIRING HARNESS REPLACEMENT INSTRUCTIONS CONTINUED

Wiring Harness
(Potter & Brumfield)
700 Board
KM1027
KM1227
GM1414
3 Phase

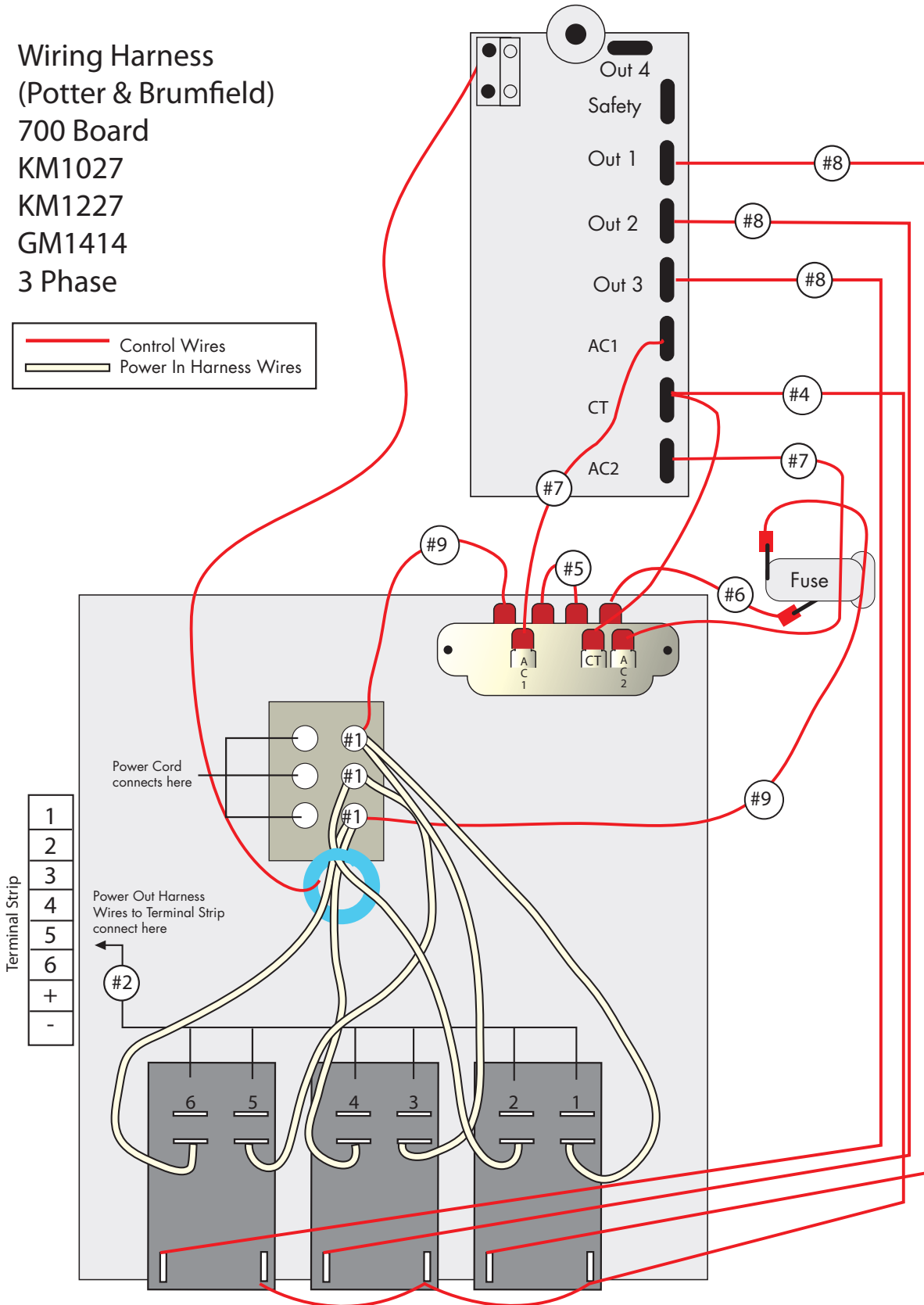

WIRING HARNESS REPLACEMENT INSTRUCTIONS CONTINUED

Wire Identification Sheet
KM1218
GM1214
1 Phase

2562

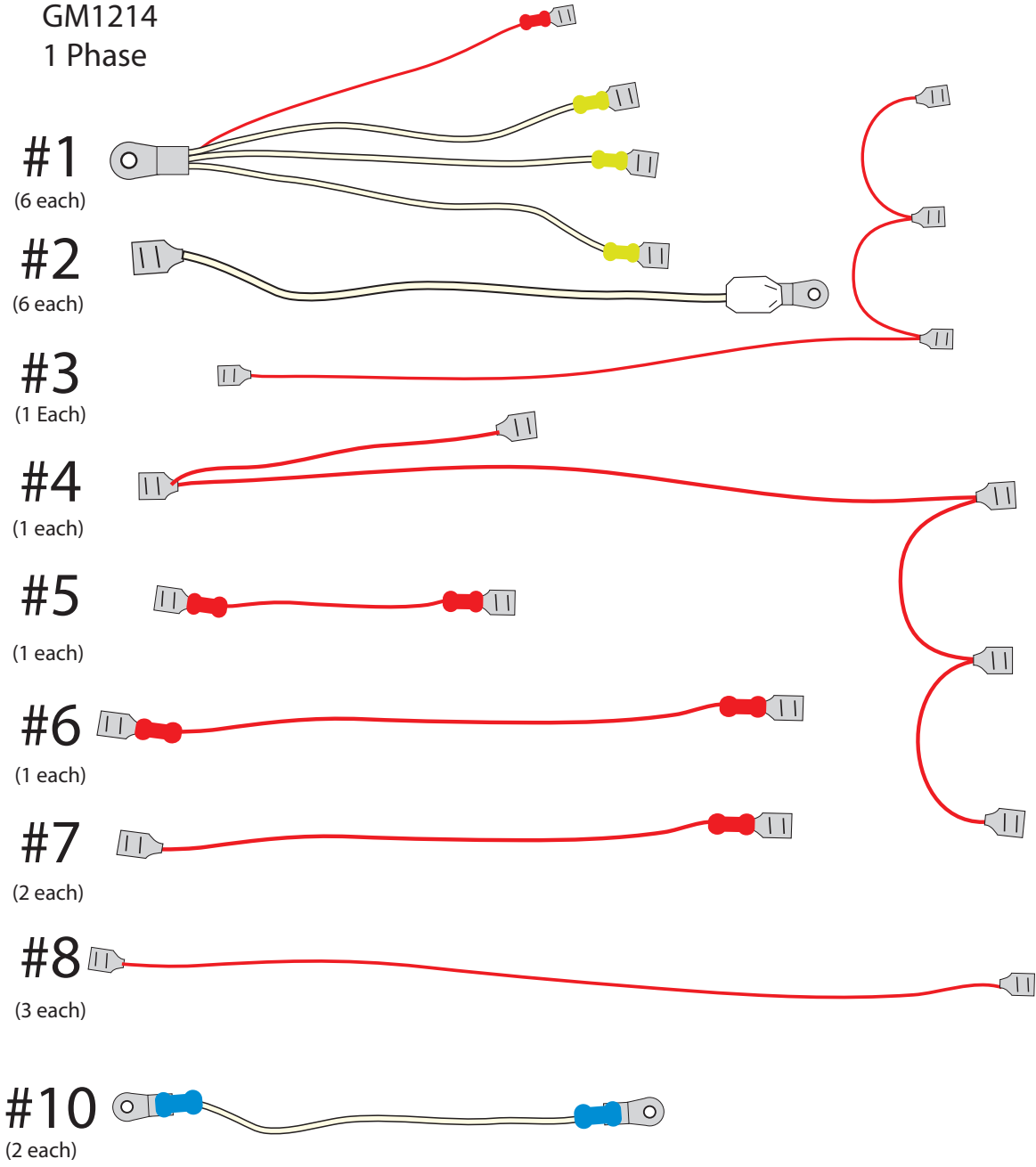

REPAIRS

WIRING HARNESS REPLACEMENT INSTRUCTIONS CONTINUED

Wire Harness (Deltrol Relays)
600 Board
KM1218
1 Phase

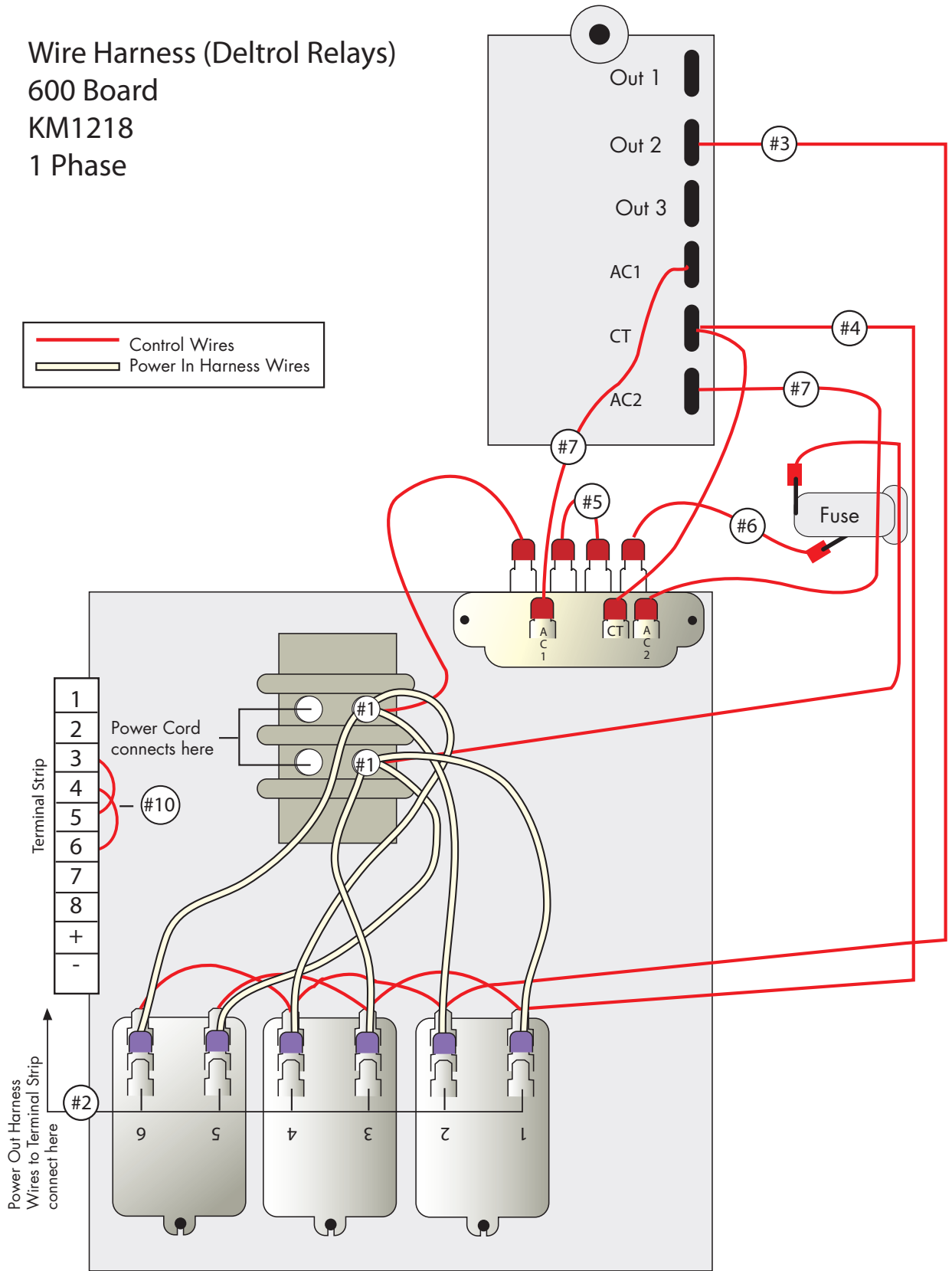

REPAIRS

WIRING HARNESS REPLACEMENT INSTRUCTIONS CONTINUED

Wire Harness (Potter & Brumfield)
600 Board
KM1218
1 Phase

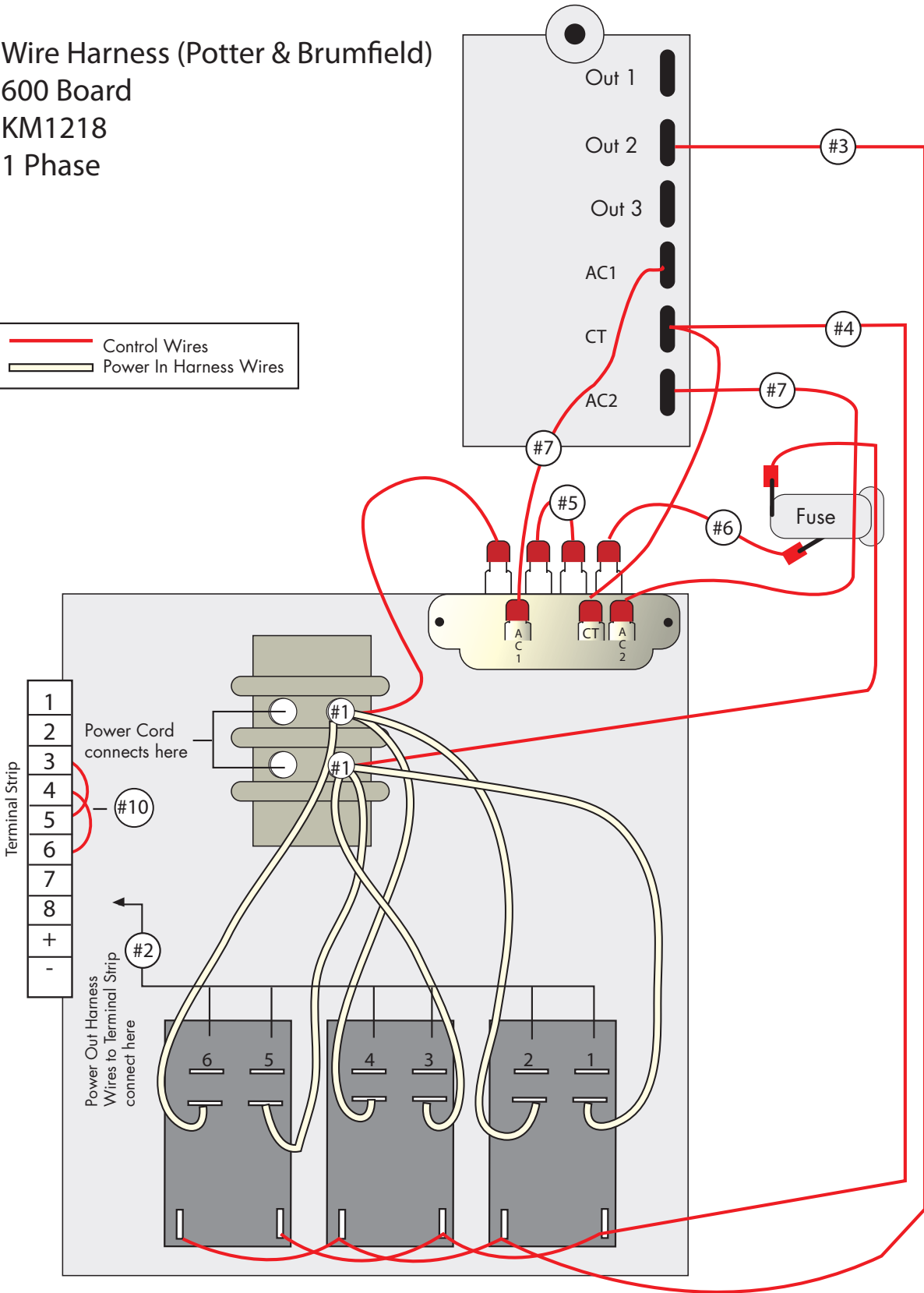
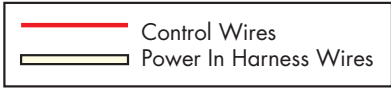

WIRING HARNESS REPLACEMENT INSTRUCTIONS CONTINUED

Wiring Harness
 (Potter & Brumfield)
 700 Board
 KM1218
 GM1214
 1 Phase

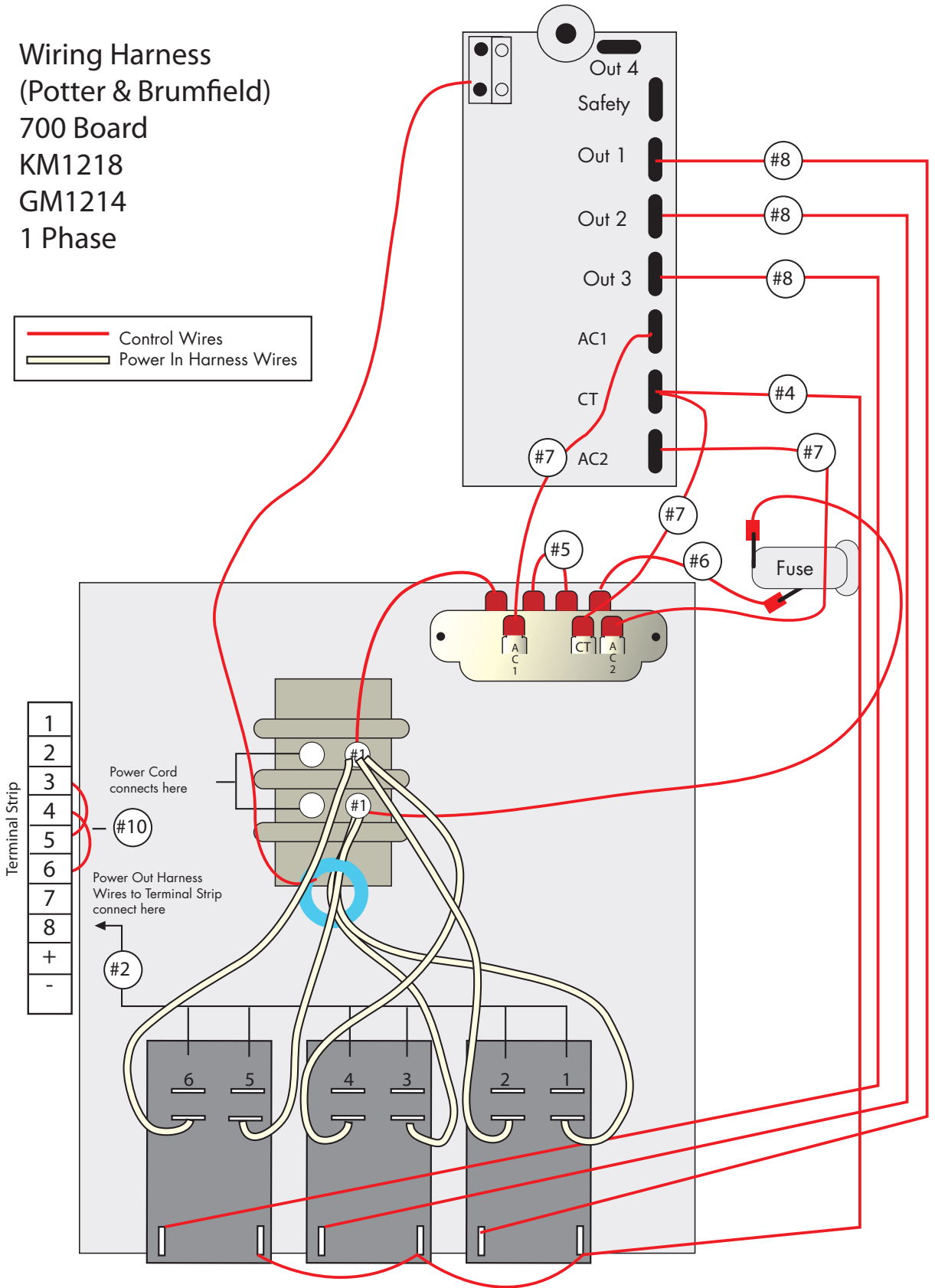

REPAIRS

WIRING HARNESS REPLACEMENT INSTRUCTIONS CONTINUED

Wire Identification Sheet
KM1218
GM1214
3 Phase

2563

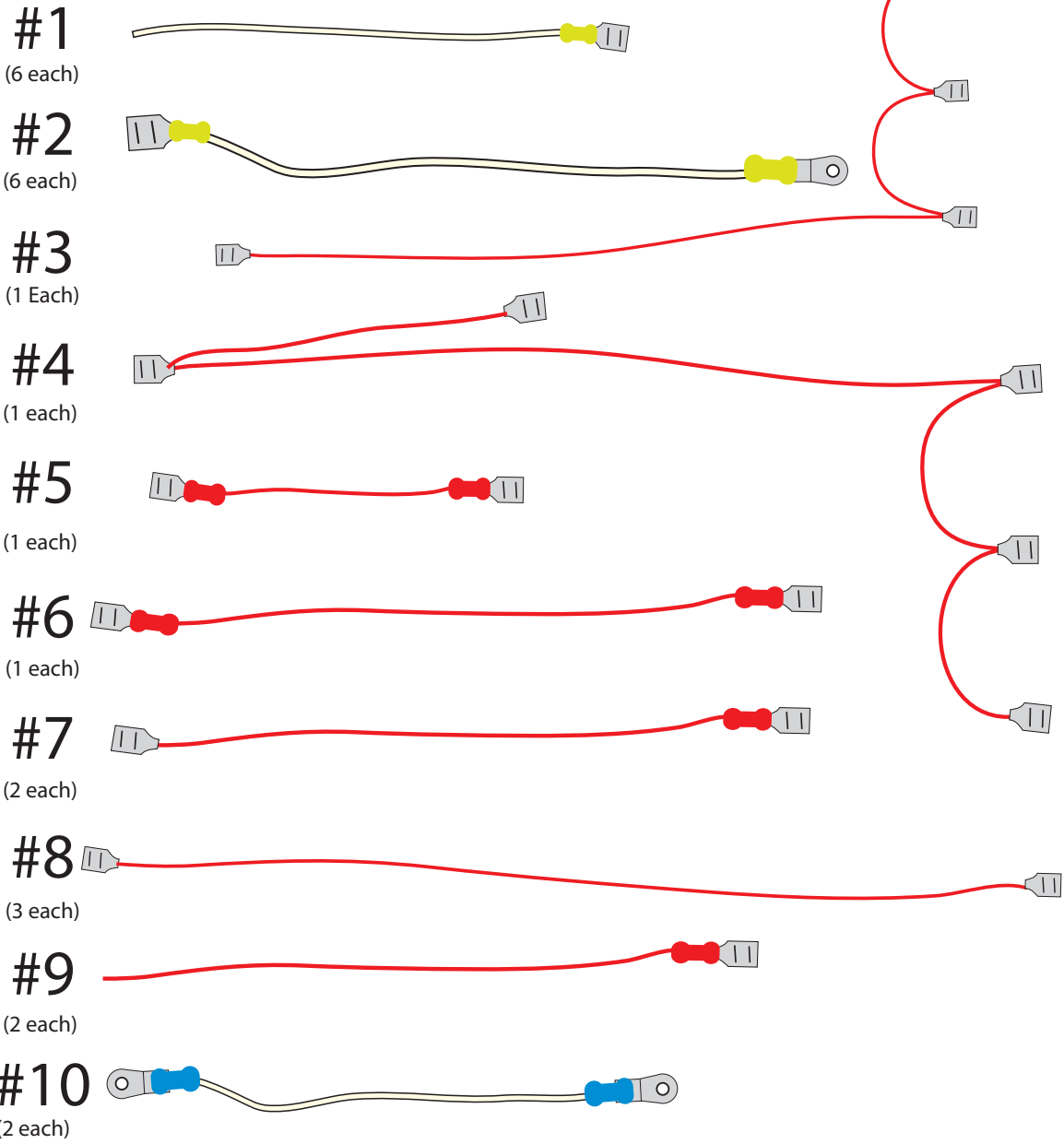

REPAIRS

WIRING HARNESS REPLACEMENT INSTRUCTIONS CONTINUED

Wire Harness (Deltrol Relays)
600 Board
KM1218
3 Phase

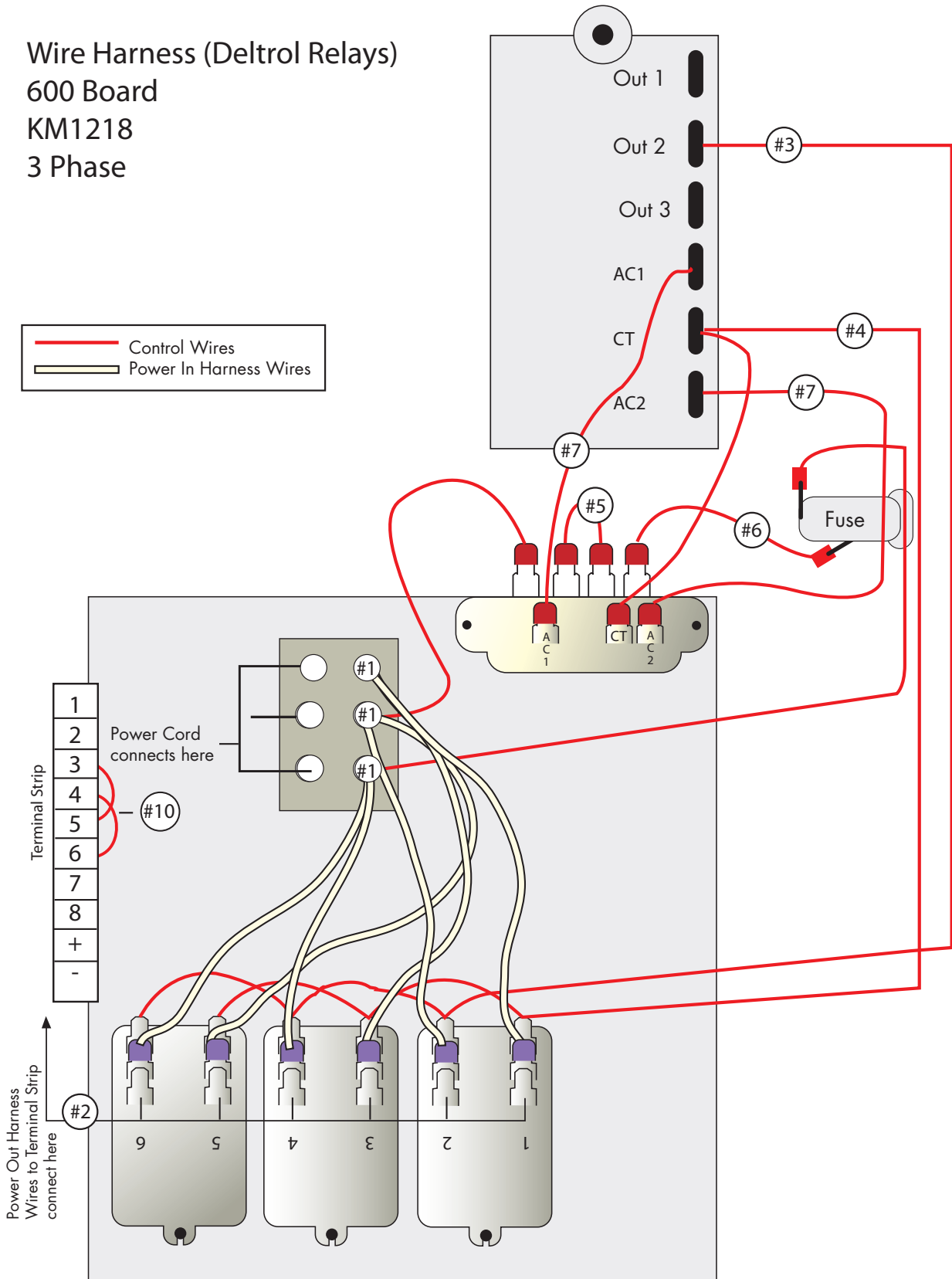

WIRING HARNESS REPLACEMENT INSTRUCTIONS CONTINUED

Wire Harness (Potter & Brumfield)
600 Board
KM1218
3 Phase

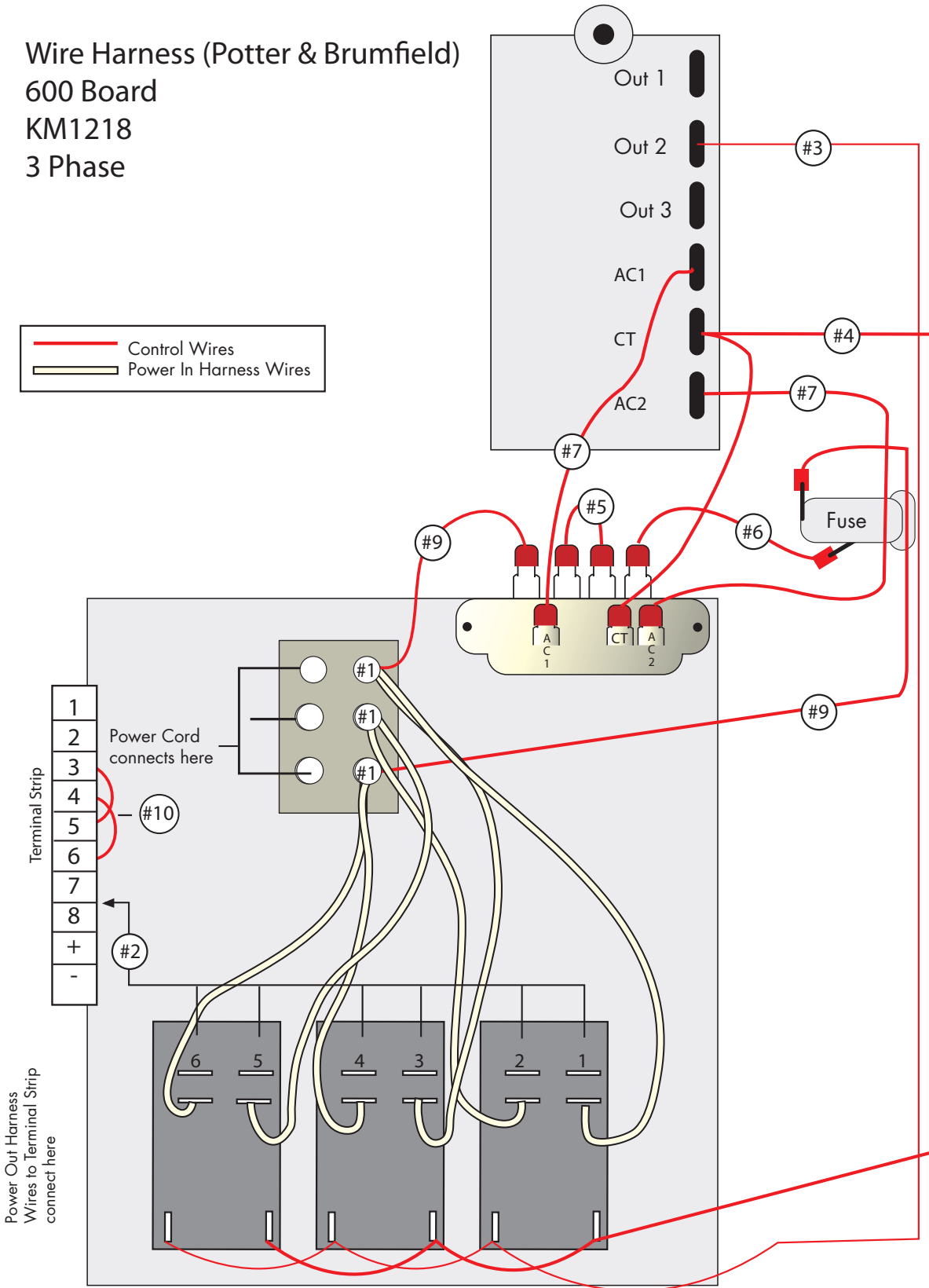
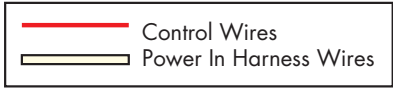

REPAIRS

WIRING HARNESS REPLACEMENT INSTRUCTIONS CONTINUED

Wiring Harness
(Potter & Brumfield)
700 Board
KM1218
3 Phase

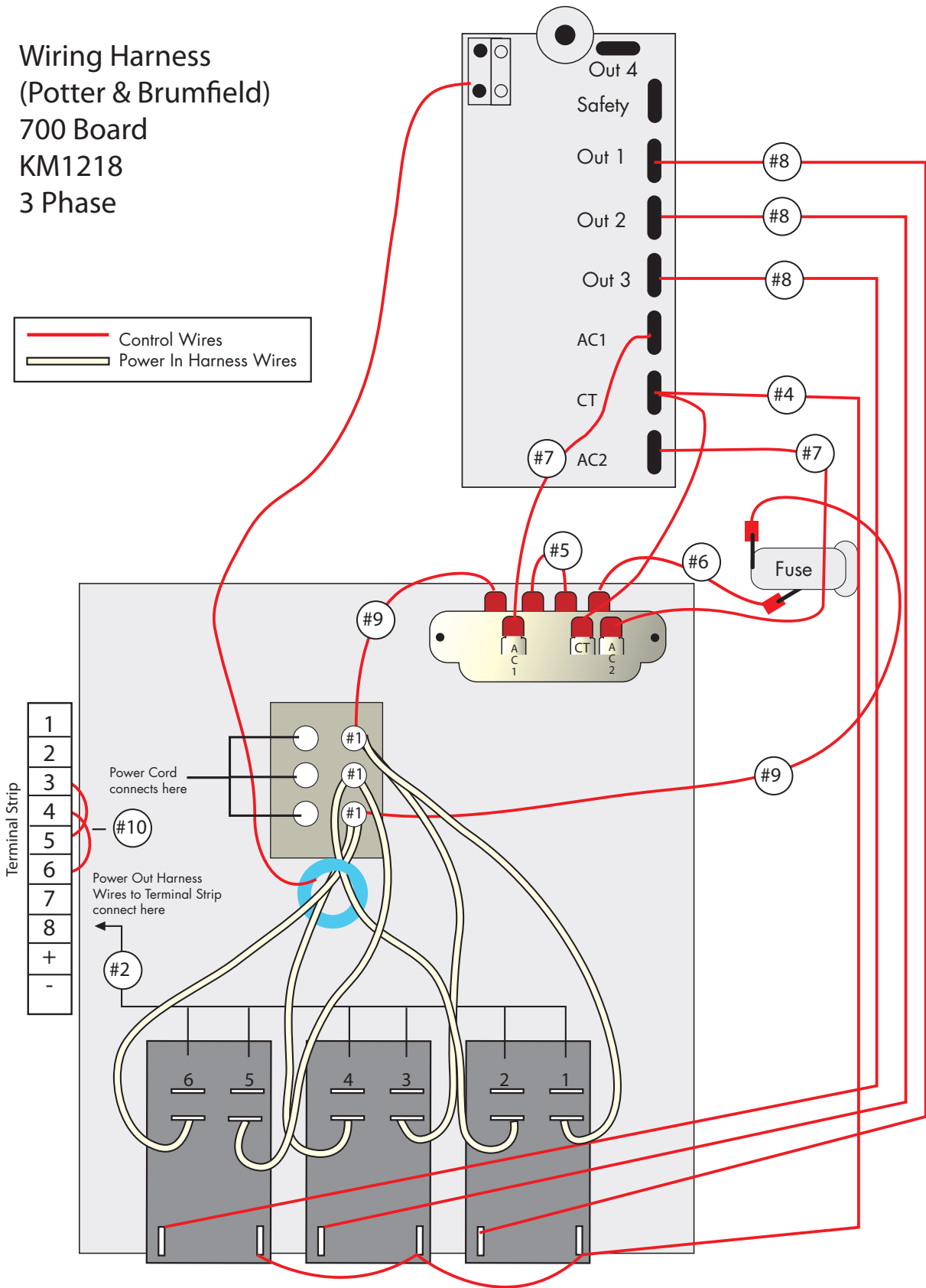

REPAIRS

WIRING HARNESS REPLACEMENT INSTRUCTIONS CONTINUED

Wire Identification Sheet
KM1018
KM818

2564

#1
(2 each)

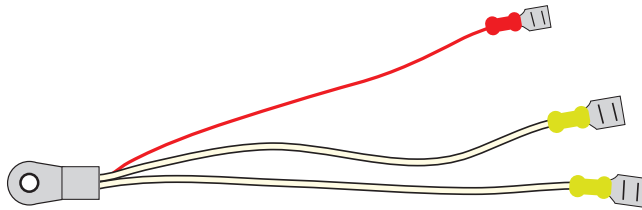

#2
(4 each)



#3
(1 Each)

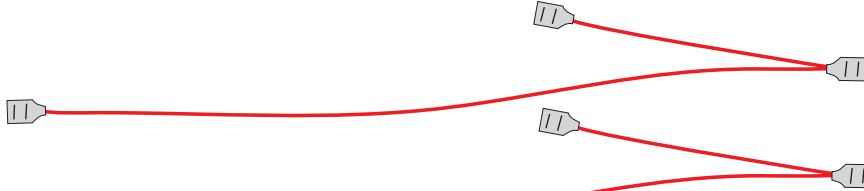

#4
(1 each)



#5
(1 each)



#6
(1 each)



#7
(2 each)



#8
(2 each)



WIRING HARNESS REPLACEMENT INSTRUCTIONS CONTINUED

Wiring Harness (Deltrol Relays)
200 Board
KM818
KM1018
1 Phase

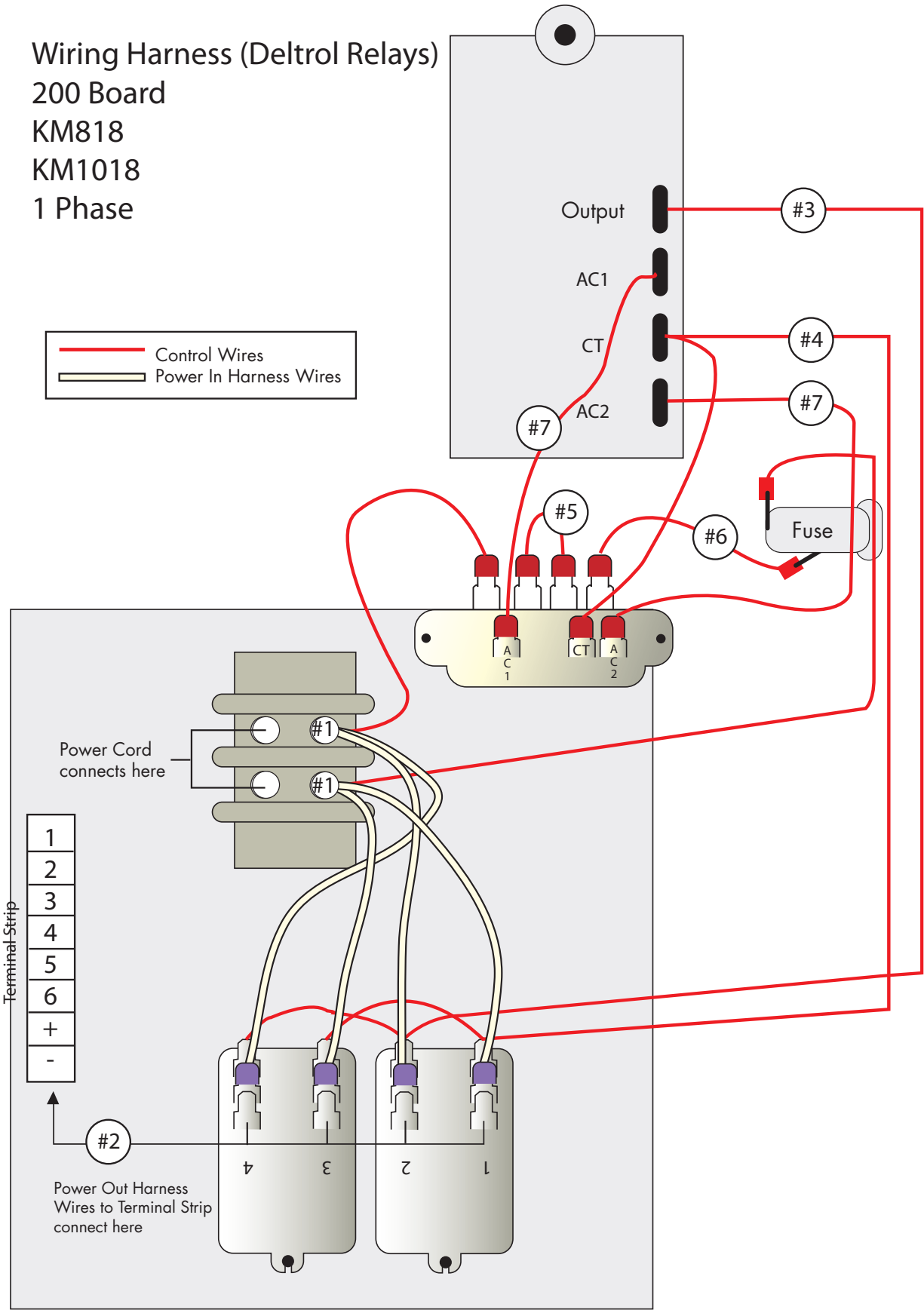

REPAIRS

WIRING HARNESS REPLACEMENT INSTRUCTIONS CONTINUED

Wiring Harness (Deltrol Relays)
300 Board
KM818
KM1018
1 Phase

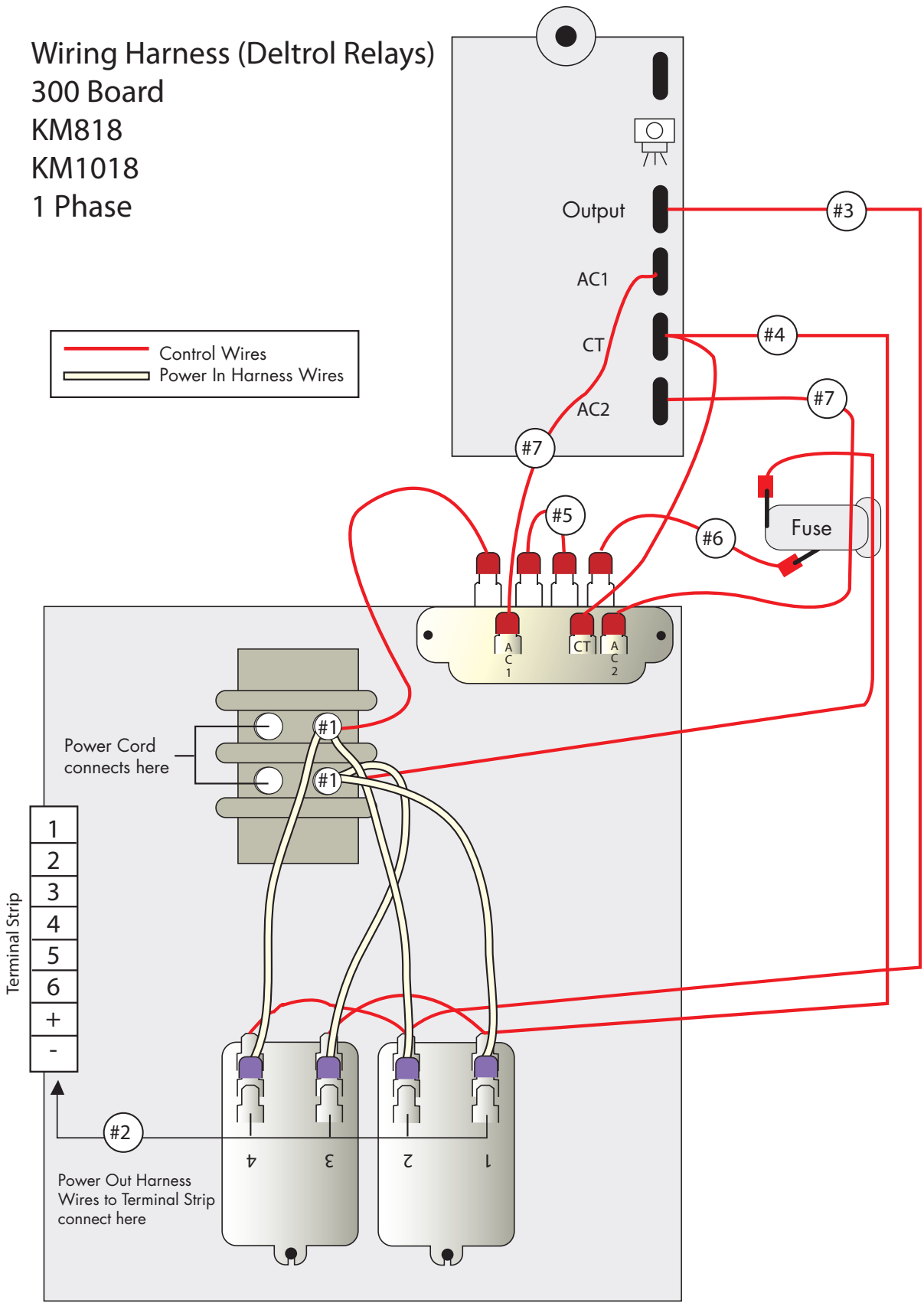

REPAIRS

WIRING HARNESS REPLACEMENT INSTRUCTIONS CONTINUED

Wire Harness (Deltrol Relays)
600 Board
KM818
KM1018
1 Phase

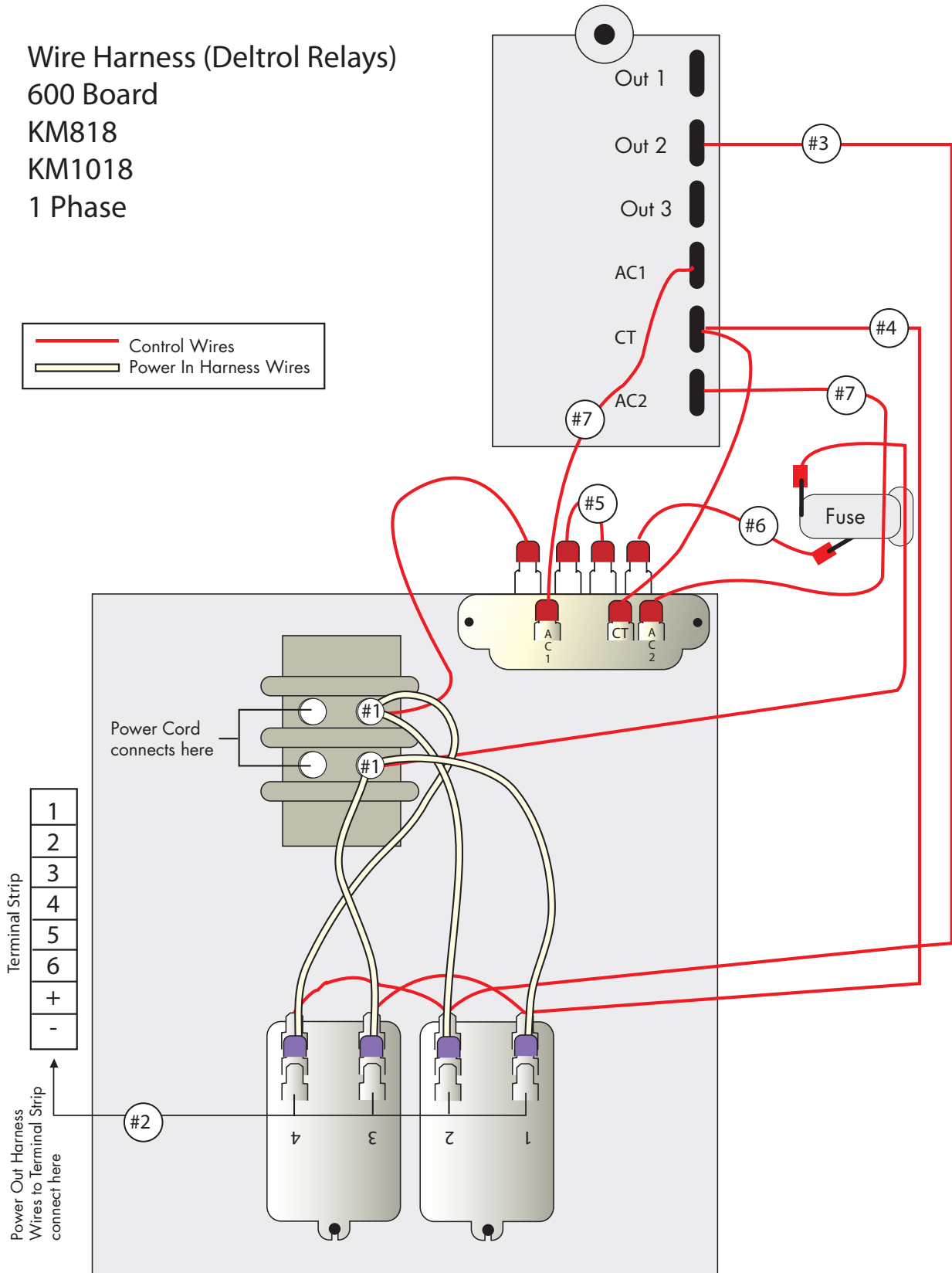

WIRING HARNESS REPLACEMENT INSTRUCTIONS CONTINUED

Wiring Harness
(Potter & Brumfield)
600 Board
KM818
KM1018
1 Phase

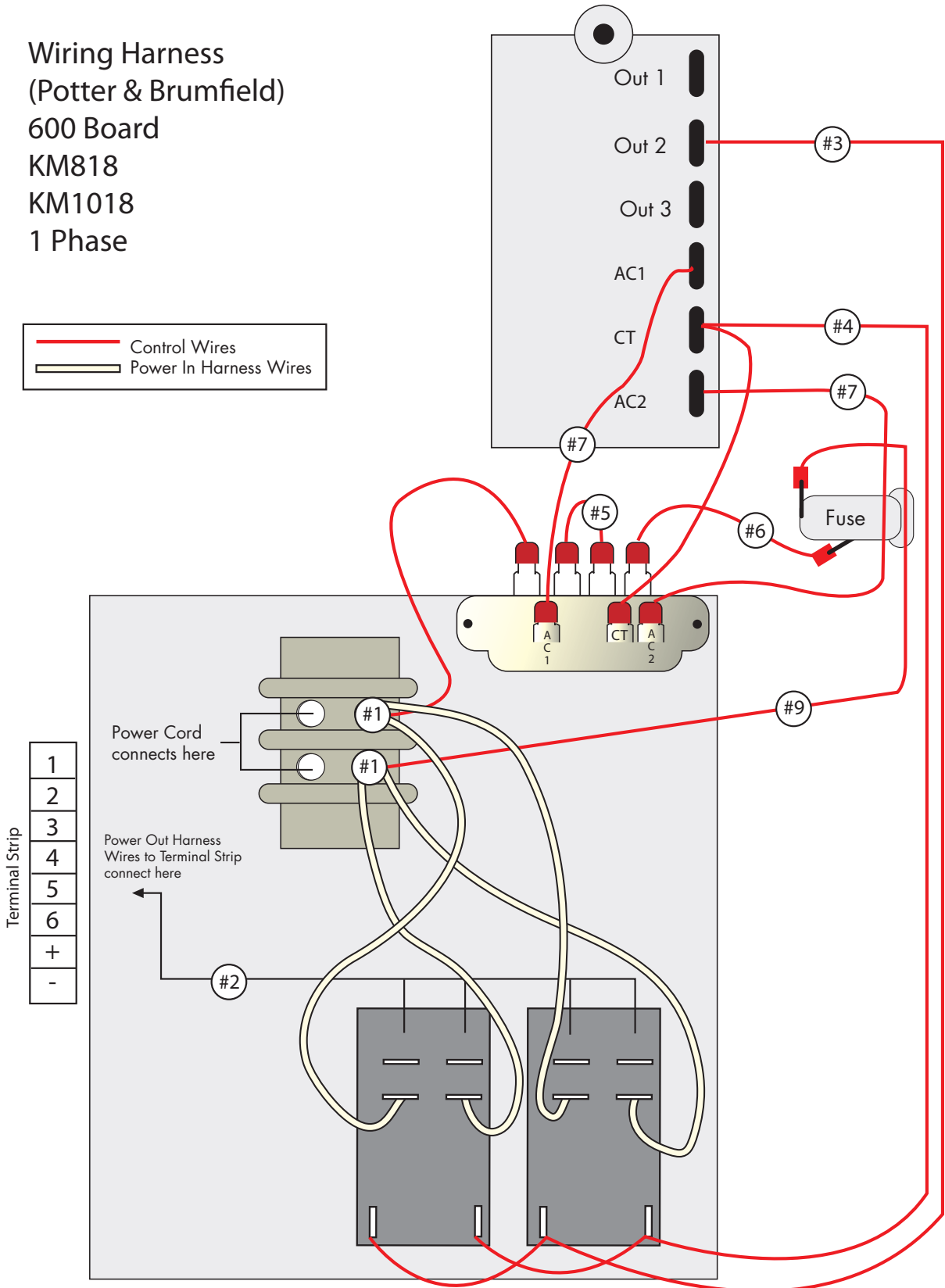

WIRING HARNESS REPLACEMENT INSTRUCTIONS CONTINUED

Wiring Harness
(Potter & Brumfield)
700 Board
KM818
KM1018
1 Phase

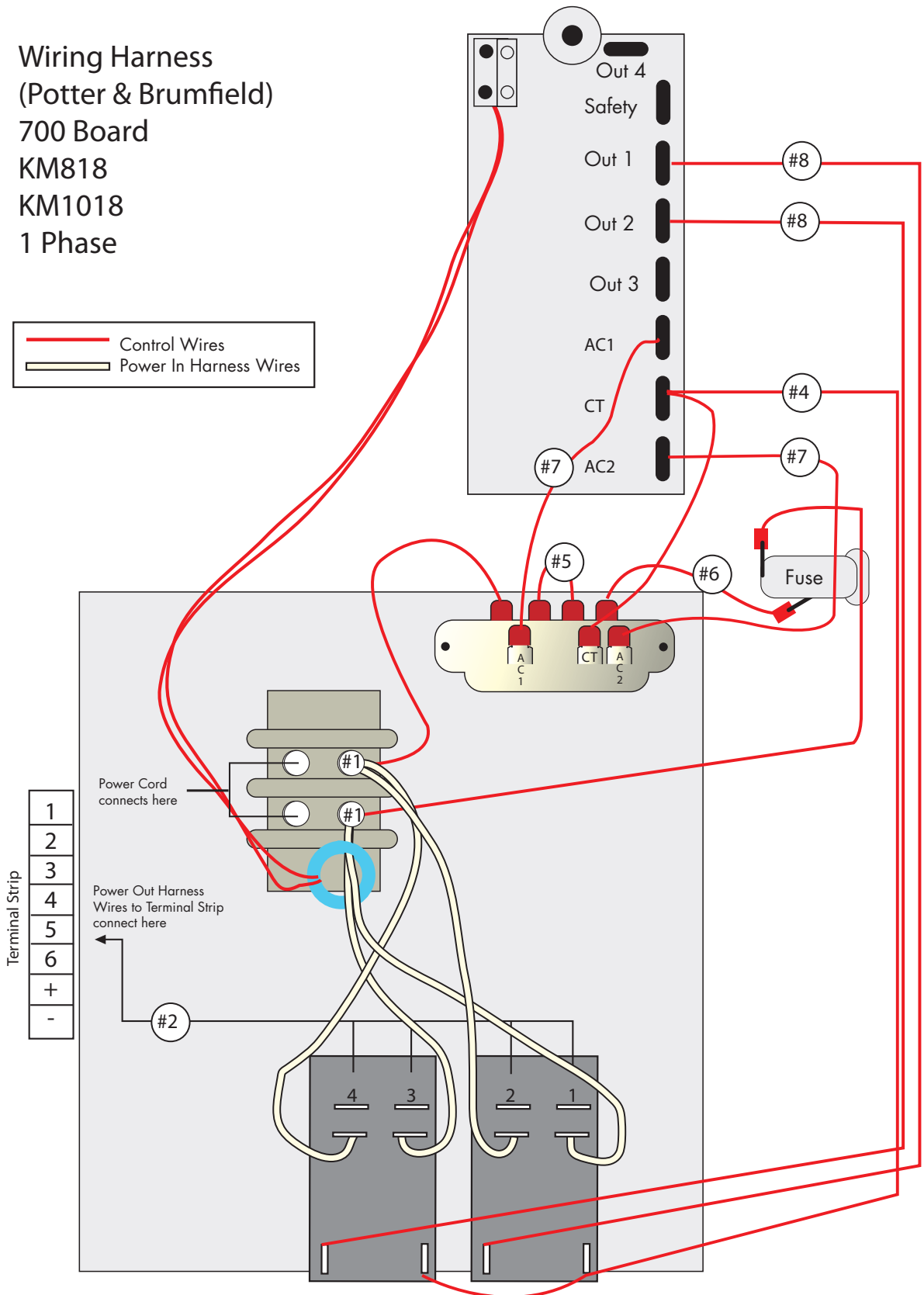

REPAIRS

WIRING HARNESS REPLACEMENT INSTRUCTIONS CONTINUED

Wire Identification Sheet
KM714

2565

#1

(4 each)



#2

(4 each)



#3

(1 Each)

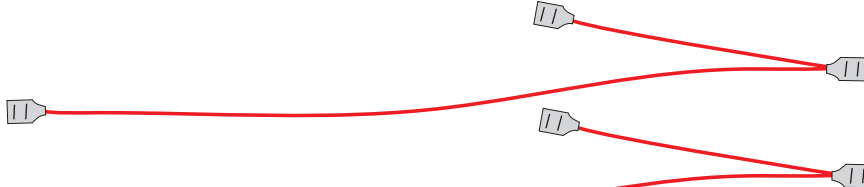

#4

(1 each)



#5

(1 each)



#6

(1 each)



#7

(2 each)



#8

(2 each)



#9

(2 each)



WIRING HARNESS REPLACEMENT INSTRUCTIONS CONTINUED

Wiring Harness (Deltrol Relays)
200 Board
KM714
1 Phase

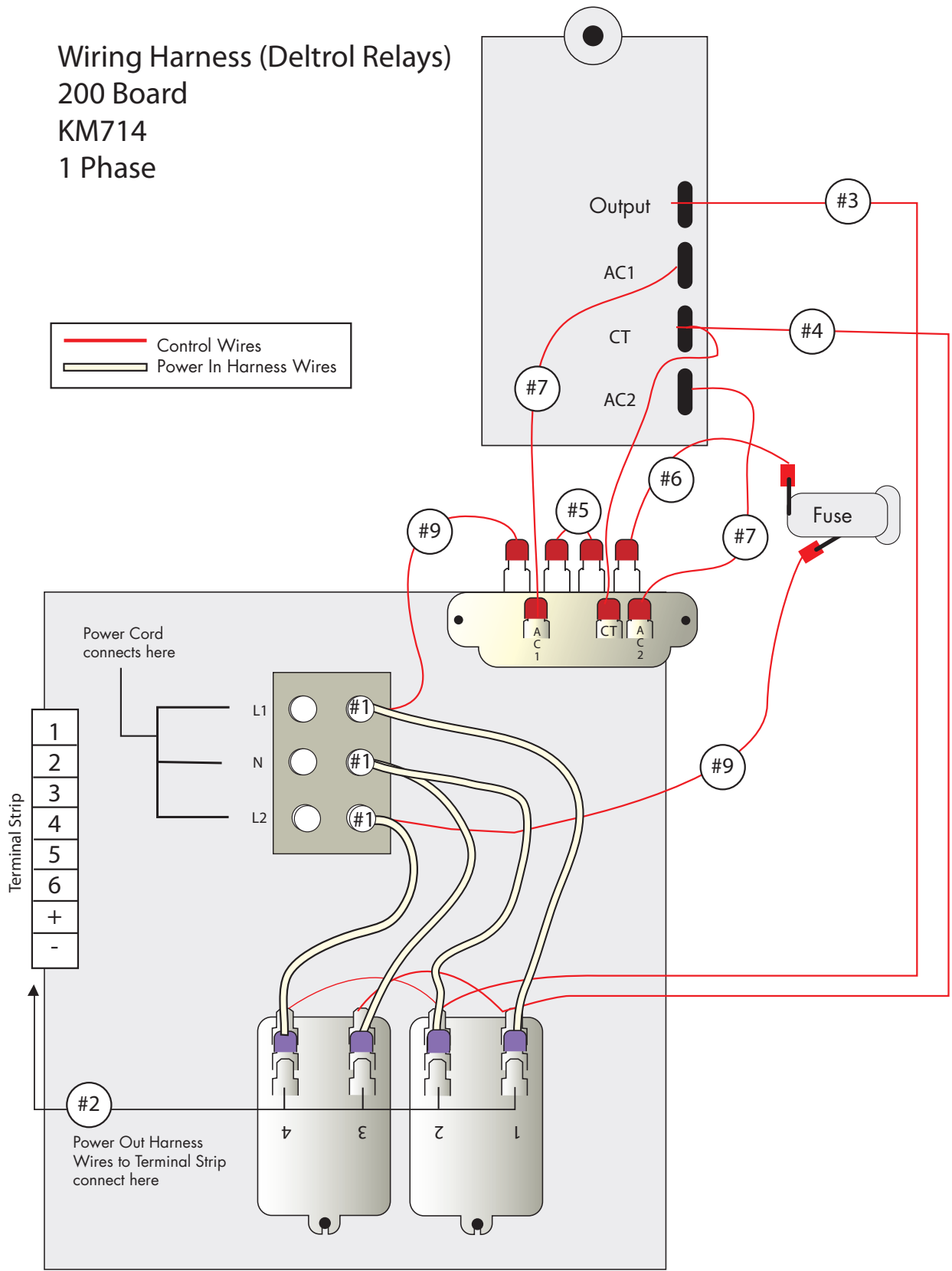

WIRING HARNESS REPLACEMENT INSTRUCTIONS CONTINUED

Wiring Harness (Deltrol Relays)
300 Board
KM714
1 Phase

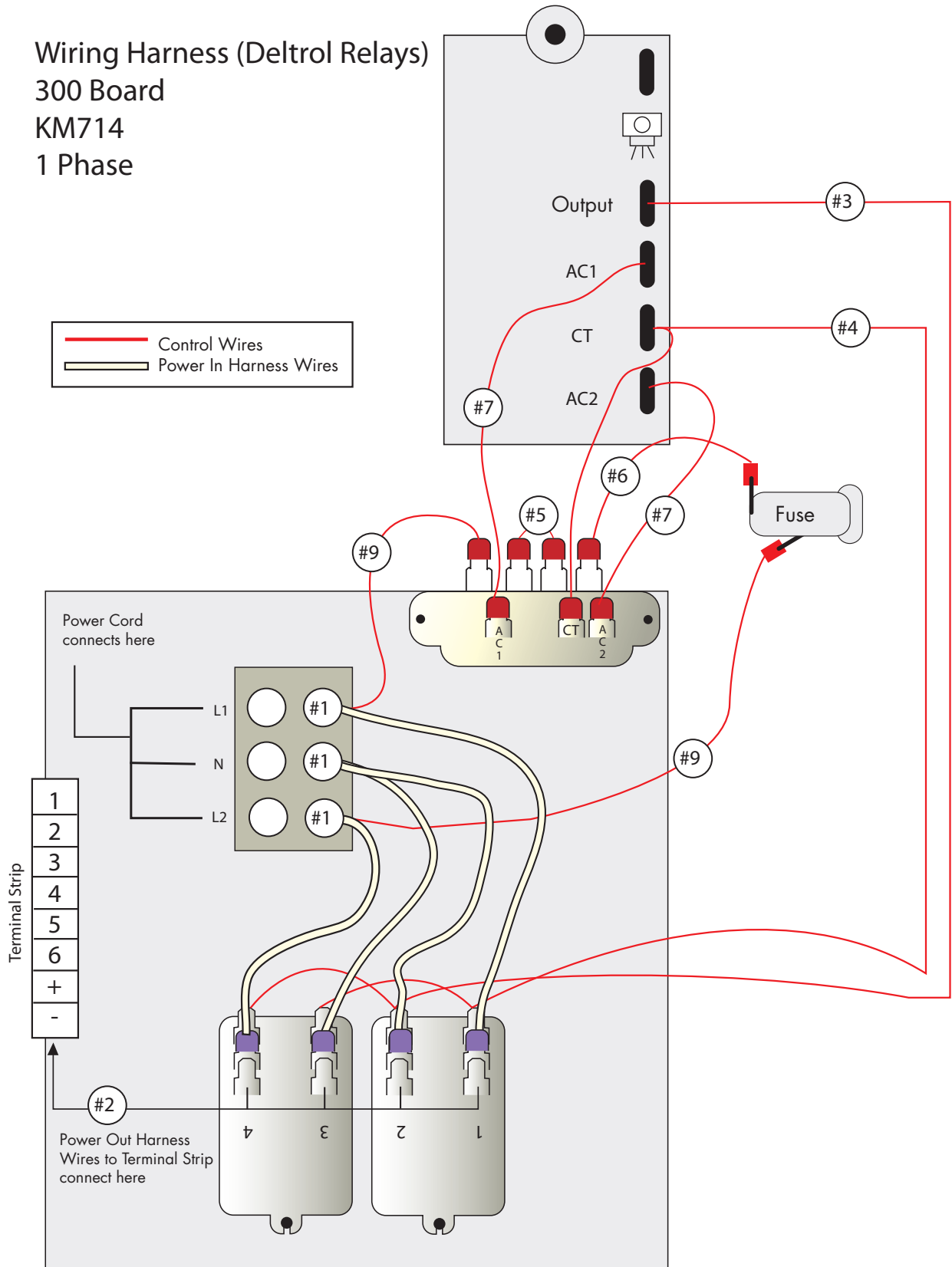
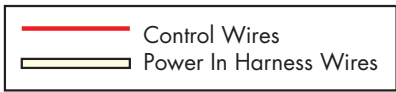

WIRING HARNESS REPLACEMENT INSTRUCTIONS CONTINUED

Wire Harness (Deltrol Relays)
600 Board
KM714
1 Phase

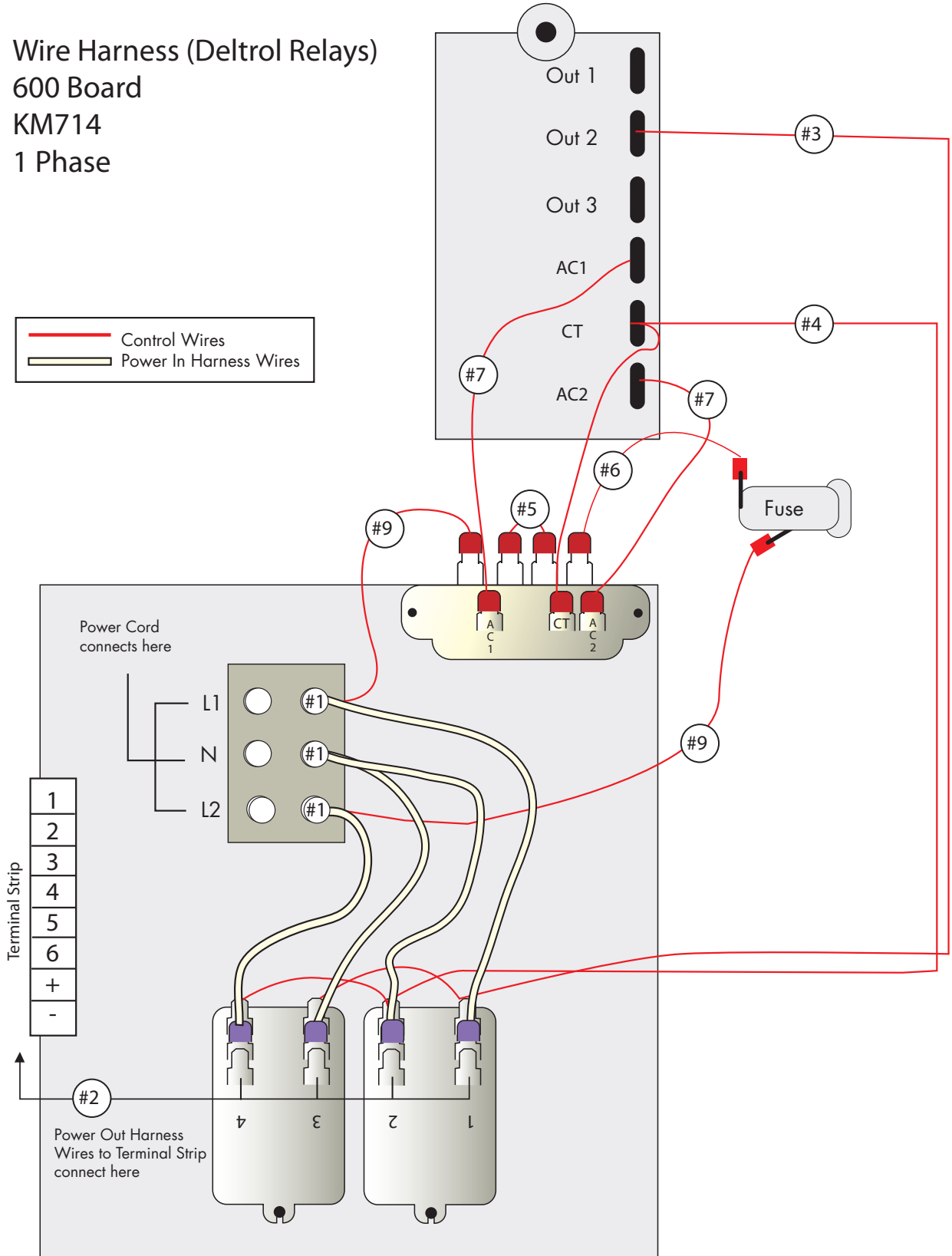

REPAIRS

WIRING HARNESS REPLACEMENT INSTRUCTIONS CONTINUED

Wiring Harness
(Potter & Brumfield)
600 Board
KM714
1 Phase

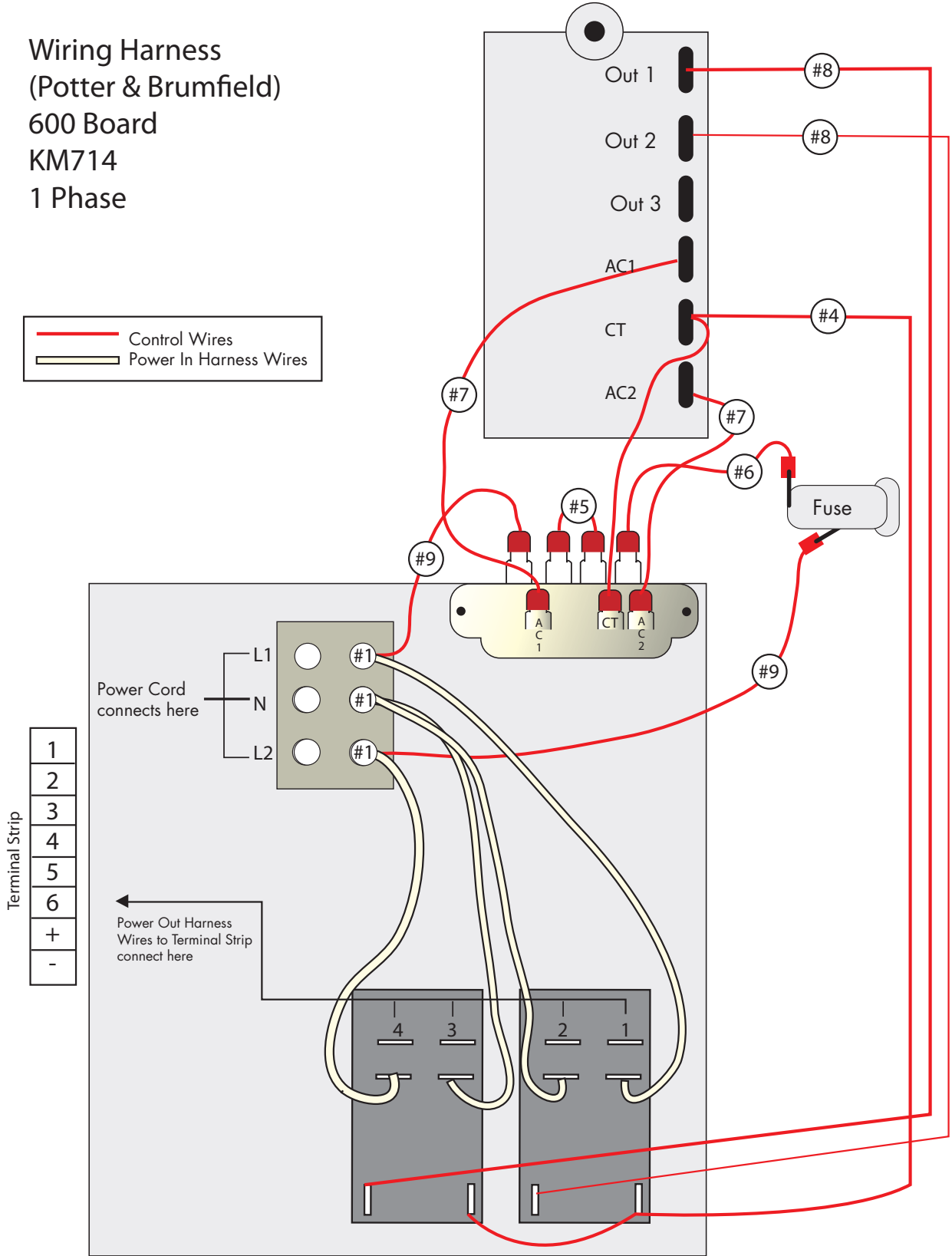

REPAIRS

WIRING HARNESS REPLACEMENT INSTRUCTIONS CONTINUED

Wiring Harness
 (Potter & Brumfield)
 700 Board
 KM714
 1 Phase

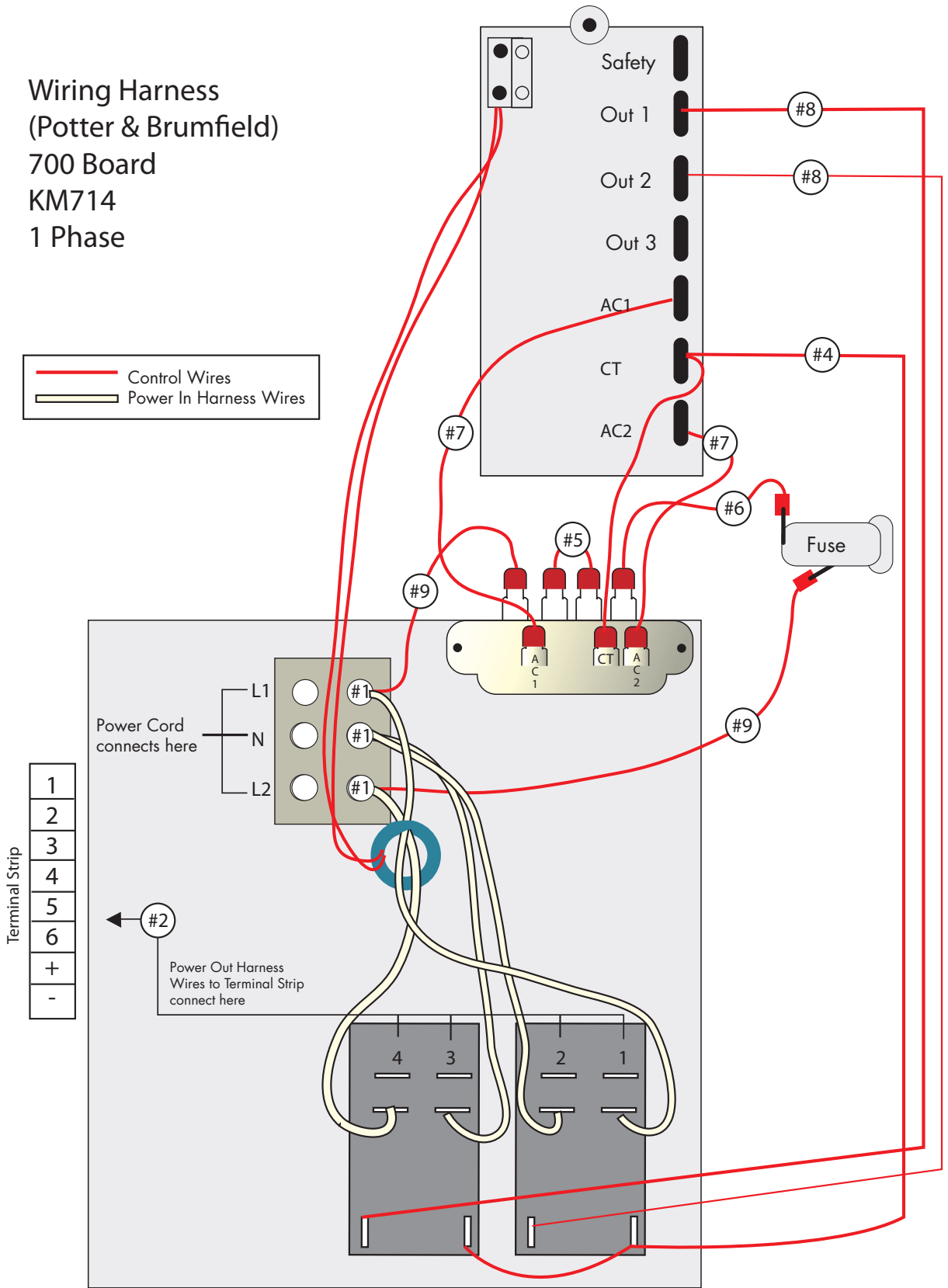

REPAIRS

WIRING HARNESS REPLACEMENT INSTRUCTIONS CONTINUED

Wire Identification Sheet
KM614-3

2566

#1

(2 each)



#2

(2each)



#3

(1 Each)

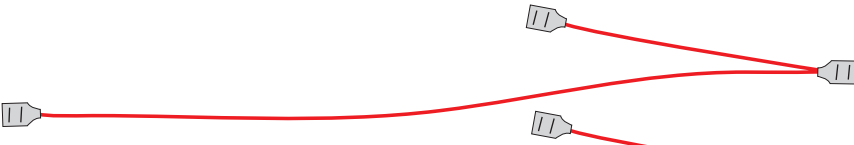

#4

(1 each)

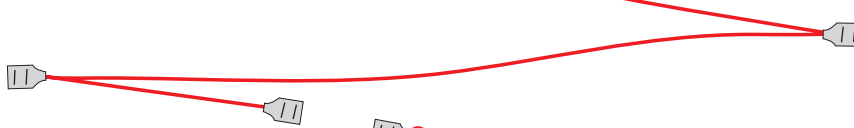

#5

(1 each)

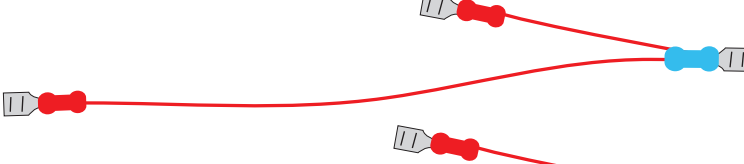

#6

(1 each)



#7

(2 each)



#8

(2 each)



#9

(1 each)



#10

(2each)



WIRING HARNESS REPLACEMENT INSTRUCTIONS CONTINUED

Wiring Harness (Deltrol Relays)
200 Board
KM614
1 Phase

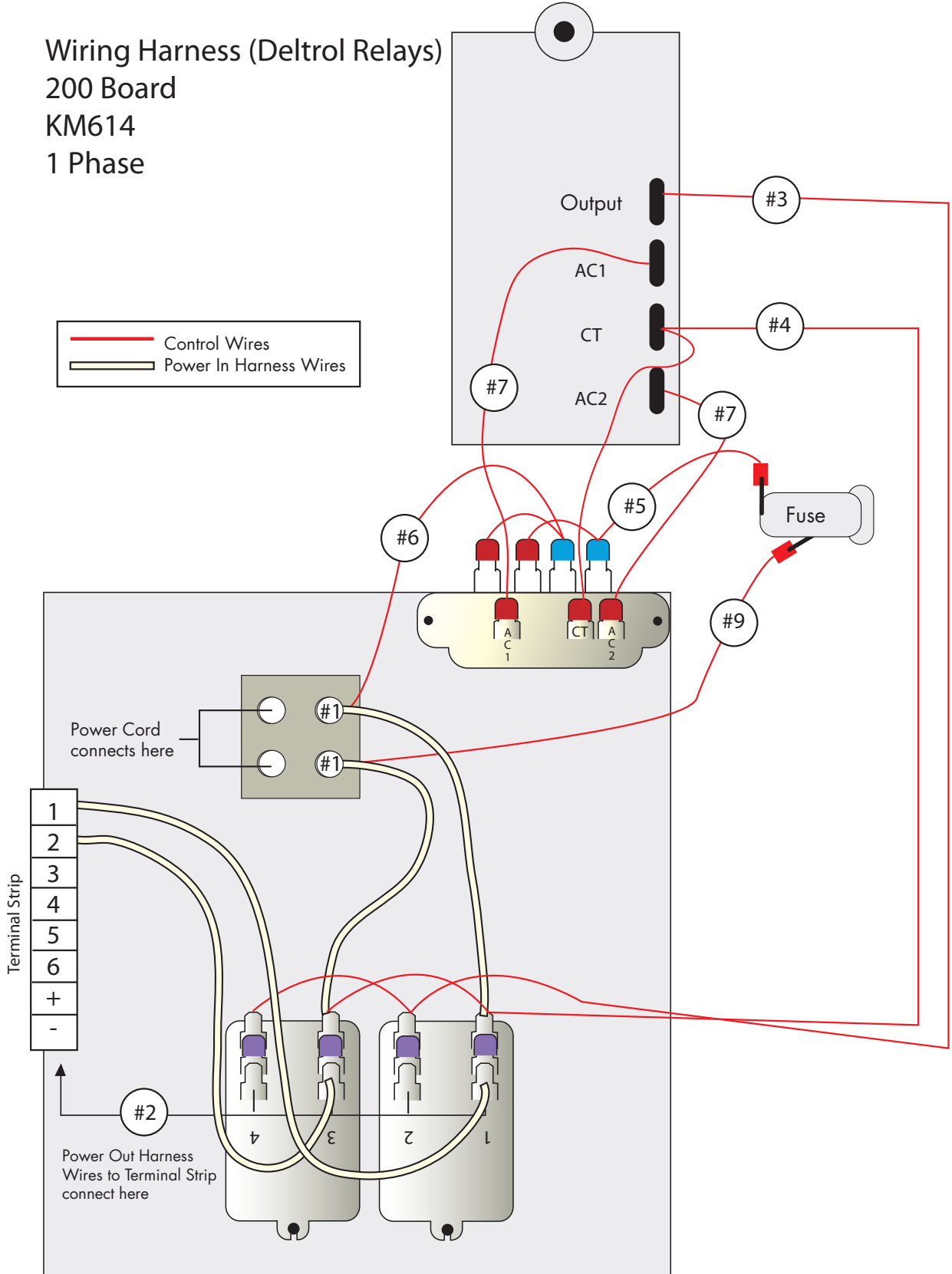

WIRING HARNESS REPLACEMENT INSTRUCTIONS CONTINUED

Wiring Harness (Deltrol Relays)
300 Board
KM614
1 Phase

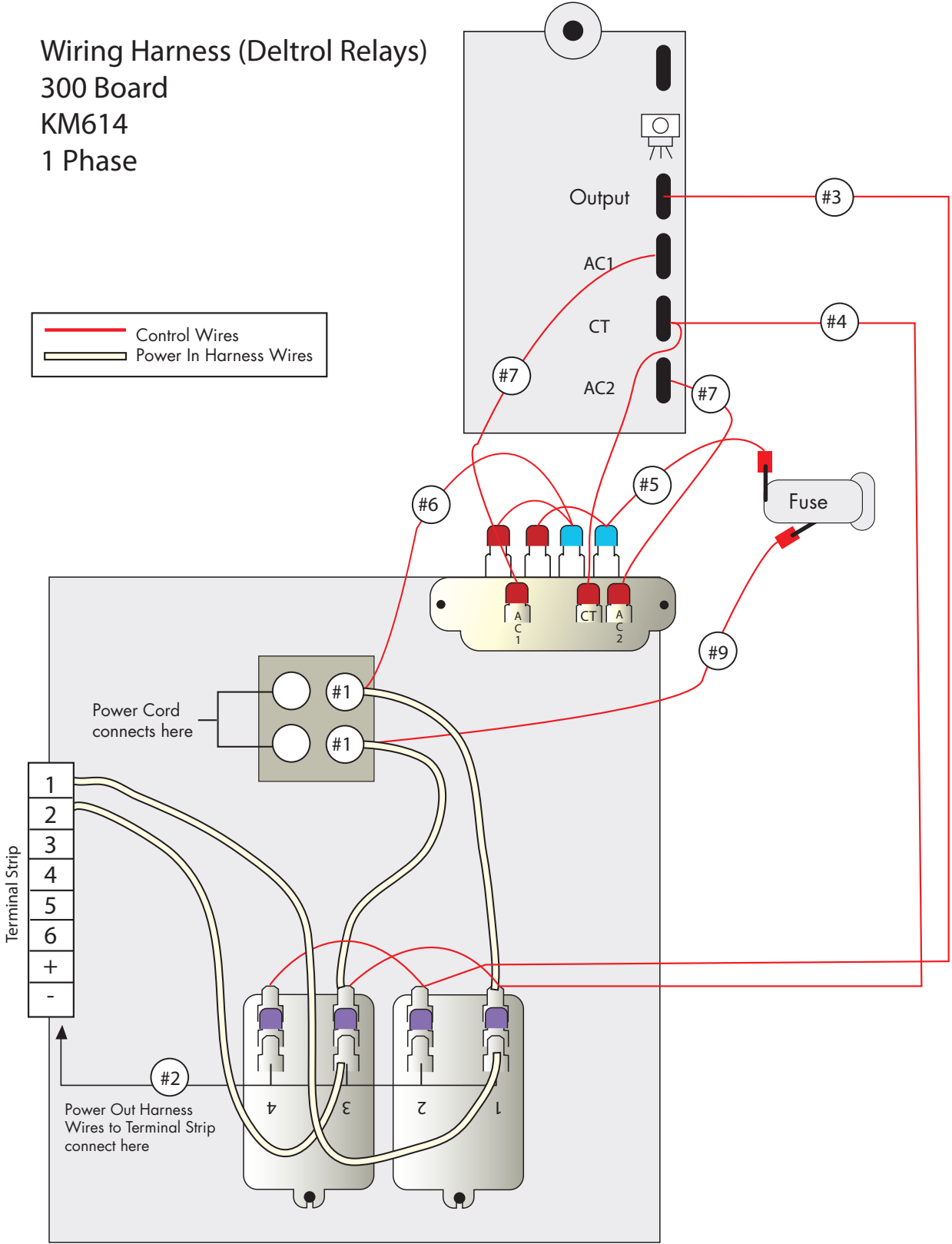

REPAIRS

WIRING HARNESS REPLACEMENT INSTRUCTIONS CONTINUED

Wire Harness (Deltrol Relays)
600 Board
KM614
1 Phase

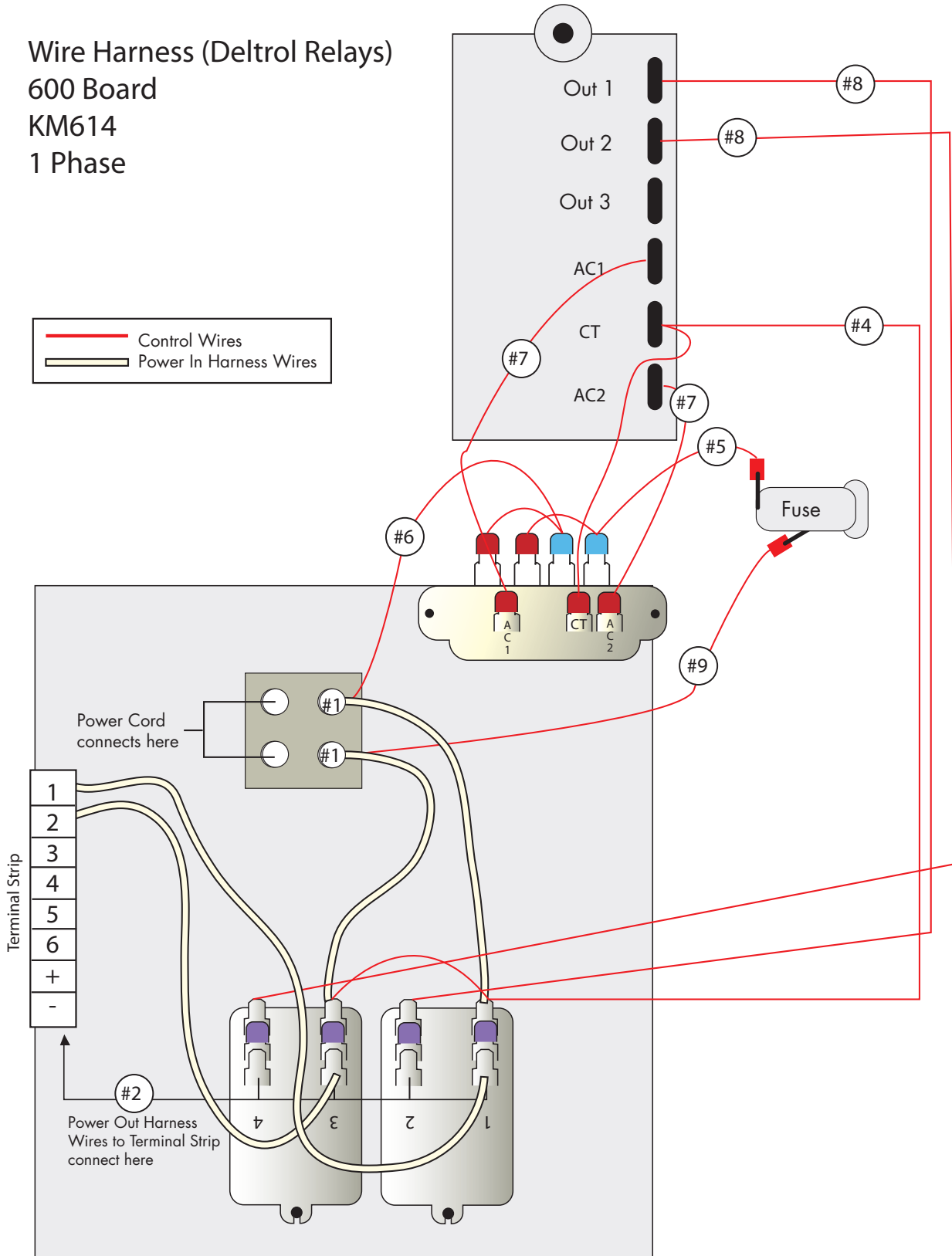

WIRING HARNESS REPLACEMENT INSTRUCTIONS CONTINUED

Wiring Harness
 (Potter & Brumfield)
 600 Board
 KM614
 1 Phase

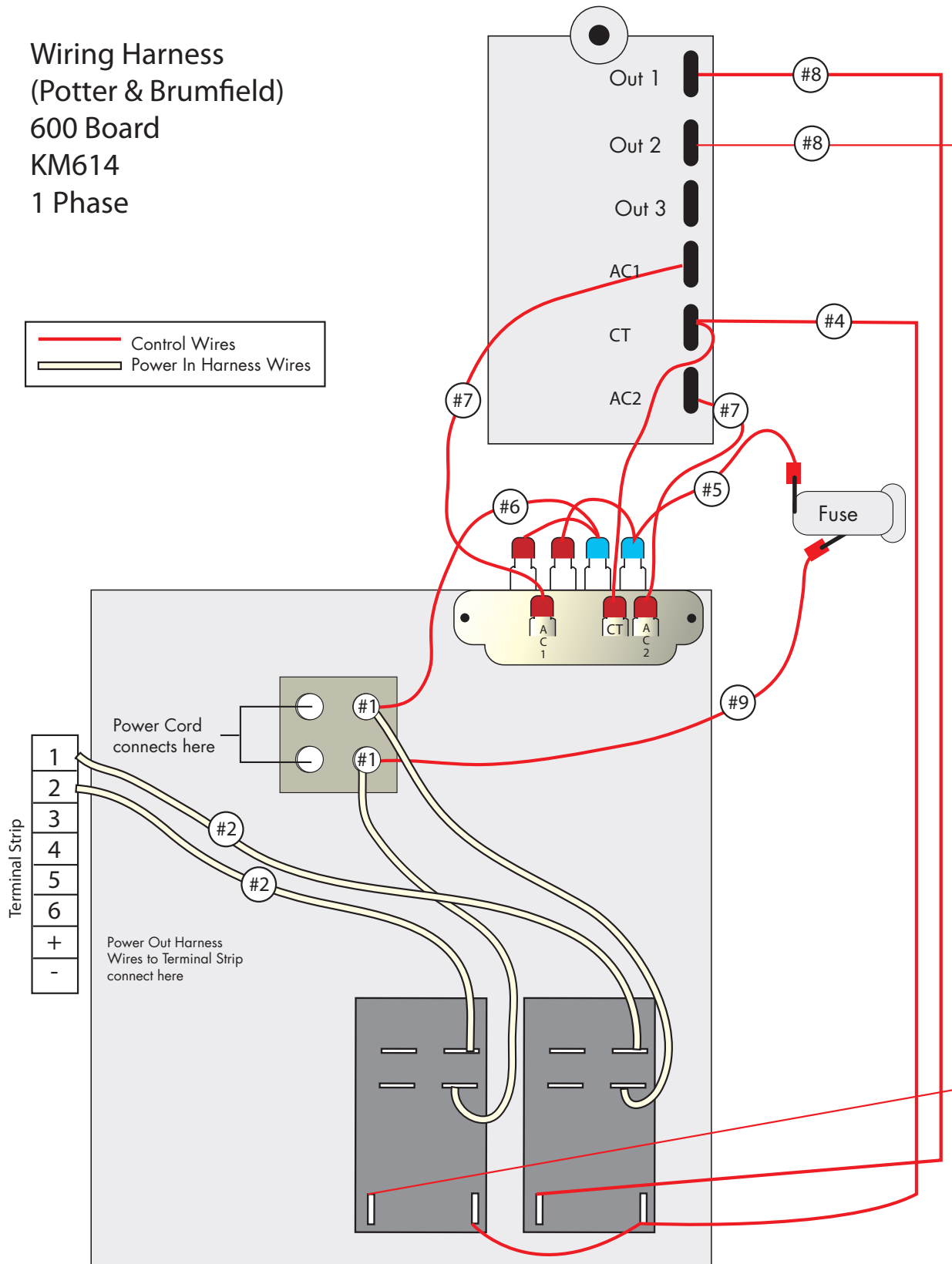

WIRING HARNESS REPLACEMENT INSTRUCTIONS CONTINUED

Wiring Harness
(Potter & Brumfield)
700 Board
KM614

